

**TOTAL  
CONTROL  
TCS SYSTEMS**

# TCS 3000 REGISTER

*"The Standard of Measurement"*

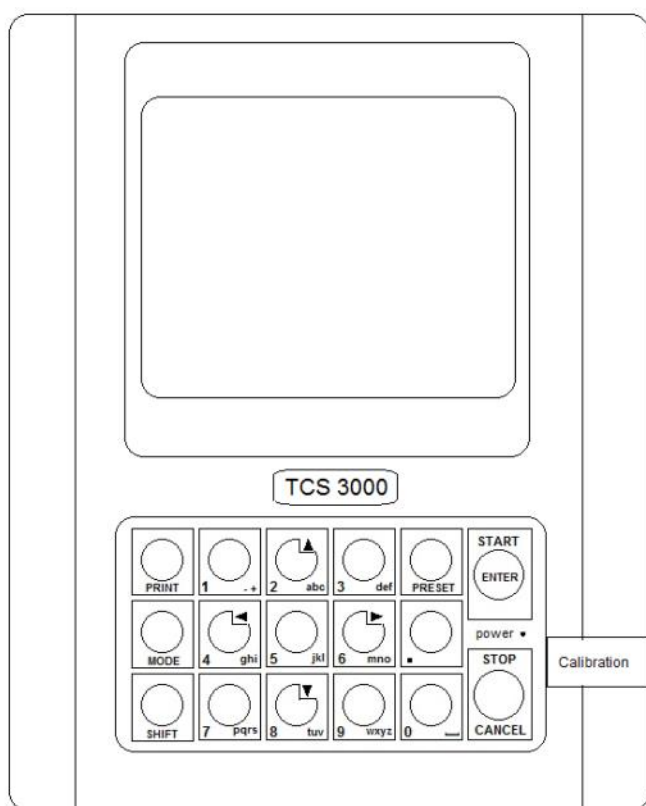

# Installation Manual

# Table of Contents

---

Table of Contents	2	Daisy Chain (Printer)	34
Receipt & Inspection	3	Daisy Chain (Modem)	36
Notice	3	Standard Wiring	38
Introduction	4	Quick Disconnect Wiring	39
System Specifications	4	Software Update	40
700 Meter	6	Warranty Information	41
682 Meter	8	Notes	42
Remote Mount	10		
Electronic Air Eliminator	12		
3-Way LPG Valve	14		
655-21 Single Stage Valve	16		
755-21 Single Stage Valve	17		
755-31 Single Stage Valve	18		
755-20 2-Stage Valve	19		
755-30 2-Stage Valve	20		
Vibronic Sensor	21		
Timing Relay	22		
Temperature Probe	23		
Printer	26		
Remote Display	33		

## Warning Symbols

---



### CAUTION

Follow the warning instructions within the following information to avoid equipment failure, personal injury or death.



### TURN POWER OFF

Before performing any maintenance, be sure to turn system power off to avoid any potential electric spark



### FLAMMABLE

Flammable liquids and their vapors may cause a fire or explosion if ignited.



### EYE PROTECTION

Pressurized systems may cause hazardous leaks and spray that may be dangerous for your eyes. Always wear eye protection around pressurized systems and its hazardous liquids.



### INJURY

Wear gloves for protection from hazardous liquids that may cause irritation or burns.



### READ

Read and understand all related manuals thoroughly. The Engineering and OIM manuals will provide the knowledge for all systems, maintenance and operation procedures. If you have any questions, please consult the factory.

## Receipt & Inspection

Upon receipt of register shipment, be sure to inspect the packaging and the register assembly for any damage before signing the receipt of the shipment. Notify the delivery company about possible damage and refuse receipt of the shipment.

Registers are individually boxed and are protected with static resistant packing material. Each package is identified with the register assembly part number, description, serial number. Verify the register model is the correct model, size, and configuration as ordered. Contact your distributor if there is any discrepancy or question.

Register assemblies should be handled with appropriate methods for the size and weight involved. Appropriate clothing and shoes need to be utilized. Transport the register package to the installation site with appropriate transportation methods, careful not to damage the register.

Be careful of any loose or protruding staples from the packaging, as they can be very sharp and may potentially cause injury.

If foam has been used to protect register, carefully remove top foam layer before attempting to remove register assembly from box. Foam packaging maybe formed around the register assembly making it difficult to remove. Do not lift the register assembly by wires or anything other than the metal body of the register. Do not insert objects or cables into the register unless stated. Removing register assembly from packaging without adhering these warnings may cause serious injury to you and/or the register.

Appropriate precautions should be taken regarding any personal, environmental and material compatibility with the end use system.

## Notice

Total Control Systems (TCS) shall not be liable for technical or editorial errors in this manual or omissions from this manual. TCS makes no warranties, express or implied, including the implied warranties of merchantability and fitness for a particular purpose with respect to this manual and, in no event, shall TCS be liable for special or consequential damages including, but not limited to, loss of production, loss of profits, etc.

The contents of this publication are presented for informational purposes only, and while every effort has been made to ensure their accuracy, they are not to be construed as warranties or guarantees, expressed or implied, regarding the products or services described herein or their use or applicability. We reserve the right to modify or improve the designs or specifications of such products at any time.

TCS does not assume responsibility for the selection, use or maintenance of any product. Responsibility for proper selection, use and maintenance of any TCS product remains solely with the purchaser and end-user.

***All rights reserved. No part of this work may be reproduced or copied in any form or by any means – graphic, electronic or mechanical – without first receiving the written permission of Total Control Systems, Fort Wayne, Indiana USA.***

## Introduction

---

The TCS 3000 register is a fully integrated custody transfer flow computer that will control all vehicle delivery operations. The Open Software Architecture provides the option of a simple “*Pump & Print*” delivery or a custom measurement solution. The TCS 3000 features a 4.5”x 3.5” full color VGA display screen, multiple delivery screens and a flexible mounting with backlit alpha-numeric keypad for the user interface. Available in flexible mounting configurations of 75 or 90 degree displays for meter mounting, and a remote mounting.

As an flow computer with open software architecture, there will always be a need to add features to the register as the industry applications evolve. Therefore please be reminded to contact the factory for periodic updates.

The TCS 3000 electronic register is a fully integrated flow computer that will control all delivery operations. The modular design and open software architecture provide you with a tailored system that is expandable for future needs. The TCS 3000 features a large easy view VGA screen, alpha-numeric keypad and open printer interface for simple “*Pump and Print*” deliveries. Software features offer complete flexibility of delivery screen information and view, preset, price/tax, ticket format and password protection.

Optional GPS, Bluetooth, Wi-Fi and Cellular capability enables the TCS 3000 to improve your product security and ease access to your delivery data to reduce your operation costs. Many additional features are available (multiple product delivery, additive injection, density/temperature correction, multiple valve & pump control, etc.) to enhance your measurement solution.

TCS 3000 - This manual will help guide you with the setup confirmation and calibration of the register. Additional information will be provided for wiring instruction and auxiliary devices to integrate into the register.

## System Specifications

---

### ELECTRICAL

Power: 12V, 4A DC INPUT

A fuse shall be provided in the field to limit the 12VDC power source to 4 amps max.

Current: 1.4 Amp

Solid State Relays: 12/24 Vdc; Passive Solid State

### INTERNAL PULSER

Pulse Ratio 400:1 PPR; Quadrature

Power 5 Vdc

Hertz 0 — 5000 Hz

### EXTERNAL PULSE INPUT

Type Single or Dual Channel (Quadrature)

Power 5 Vdc

### ENCLOSURE

Aluminum die cast with epoxy powder coat

Built to Ingress Protection 66 and Nema 4 ratings

Temperature Range: -40 F to 158 F (-40 C to 70 C)

Ports: Ten 1/2” NPT UL, cUL threaded connection ports, ATEX

Backlit LED Keypad

Calibration optical switch, password and mechanical seal

UL/cUL Rating Class 1, Division 2, Group C + D

The USB0 and USB1 connectors are for maintenance only. To access these connectors, power to the unit is to be Disconnected or the area known to be free of ignitable gas or equivalent.

## COMMUNICATION

Four RS 485 output, 2-wire half duplex, custom protocol; 9600 baud, 8 bit, no parity, 1 stop bit

One RS 232 output, 9600 baud; 8 bit, no parity, 1 stop bit

## WARNINGS:

SUITABLE FOR USE IN CLASS 1, DIVISION 2, GROUPS C AND D HAZARDOUS LOCATIONS, OR UNCLASSIFIED LOCATIONS.

WARNING– EXPLOSION HAZARD– DO NOT DISCONNECT EQUIPMENT WHILE THE CIRCUIT IS LIVE OR UNLESS THE AREA IS KNOWN TO BE FREE OF IGNITABLE CONCENTRATIONS

WARNING– EXPLOSION HAZARD– SUBSTITUTION OF ANY COMPONENT MAY IMPAIR SUITABILITY FOR CLASS 1, DIVISION 2.

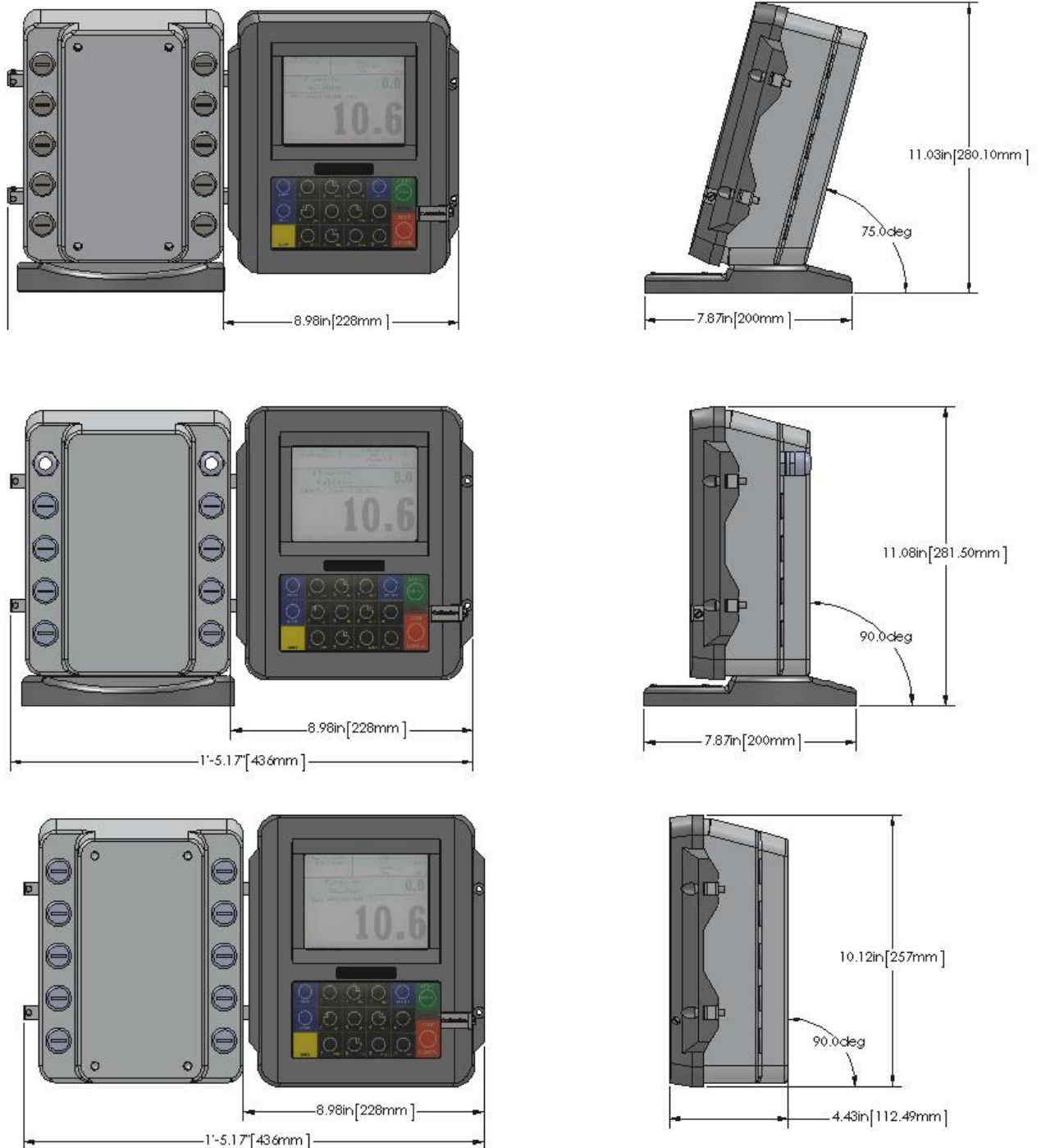

## Installation Procedure—TCS 700 Series Meter



Before beginning the installation of the TCS 3000, unpack the entire contents of the packaging in a safe location where you will not misplace any of the parts. Lay out the parts as they would be installed on the truck. This will ensure that you have all the correct parts for the installation. Verifying all the necessary parts were included in the shipment in advance will reduce the truck downtime and avoid any wasted truck preparation work.

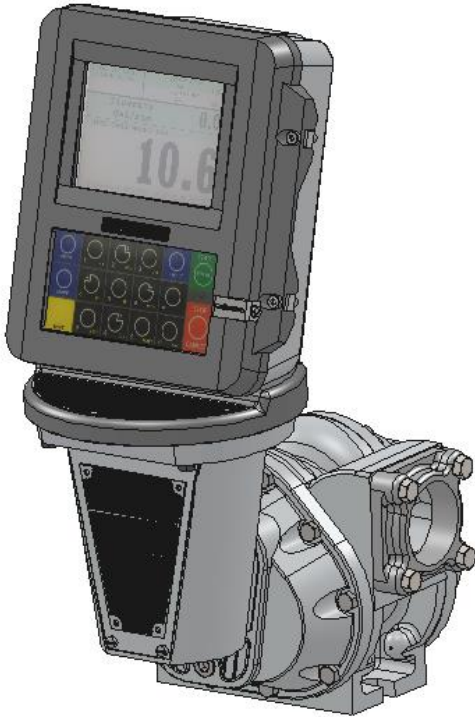

Item	Qty	TCS P/N
Phillips Pan MS M4X8	6	TCS300137
Spring Washer M4	6	TCS300138
Terminal Cover	1	TCS300164
3000 Reg. 7.5 AMP Fuse	1	TCS300192
3000 Reg. Fuse Holder	1	TCS300193
Cable Gland, M12	4	TCS300244
O-Ring, M12	4	TCS300245
USB Fem/Mini Male Cable	1	TCS300705
Resistor 1K OHM	2	TCS300753
1/4—28X1 Zinc Bolt	2	TCS68013
1/4-28X1 Drilled Bolt	2	TCS68013D
3/64 X 1 Cotter Pin	1	TCS790091
3000:700 Meter Drive Shaft	1	TCS790092

TCS 3000 to TCS 700 Meter Install Kit (TCS300870)

### Installation Procedure:

1. Remove and put aside the four mounting bolts and any mounting adaptor. Remove the existing mechanical register or electronic register, if applicable. Use a box or container to set old equipment and parts in.
2. Remove adjuster dust cover plate from the front of the meter. Remove existing adjuster and drive shaft. Set adjuster dust cover aside in a box or container where it will not be misplaced. Screw the screws back into meter unit. Notice the type of vertical drive shaft in the meter.
3. Using the shaft specific to your installation, slide the Drive Shaft Adaptor on the Pulser and align the holes. Once the holes are aligned insert the Cotter Pin and bend the pin ends back around the Shaft Adaptor.
4. Slide the Adaptor onto the Meter Drive Shaft.
5. Rotate the TCS 3000 until the display is facing in the desired direction and check to see that the meter holes align with the holes at the base of the TCS 3000.
6. Secure the bolts.

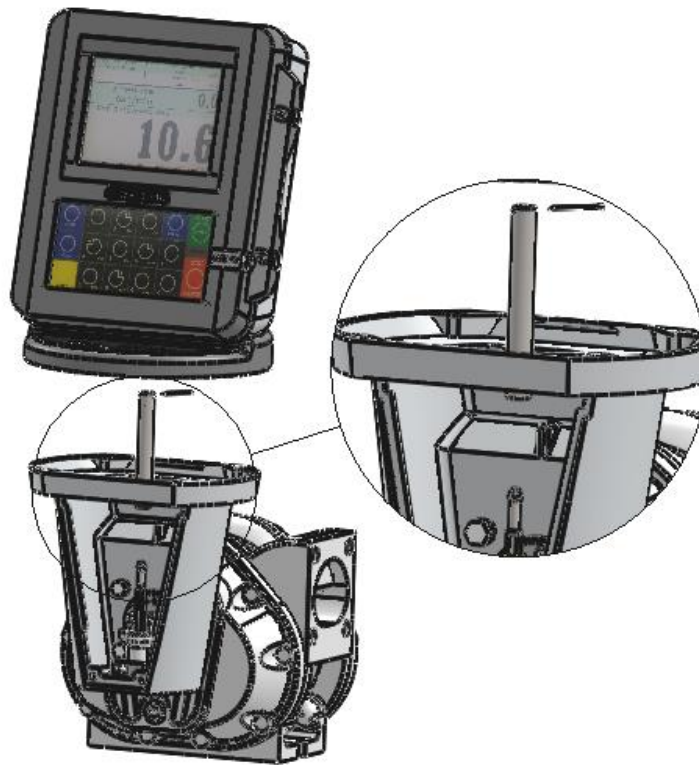
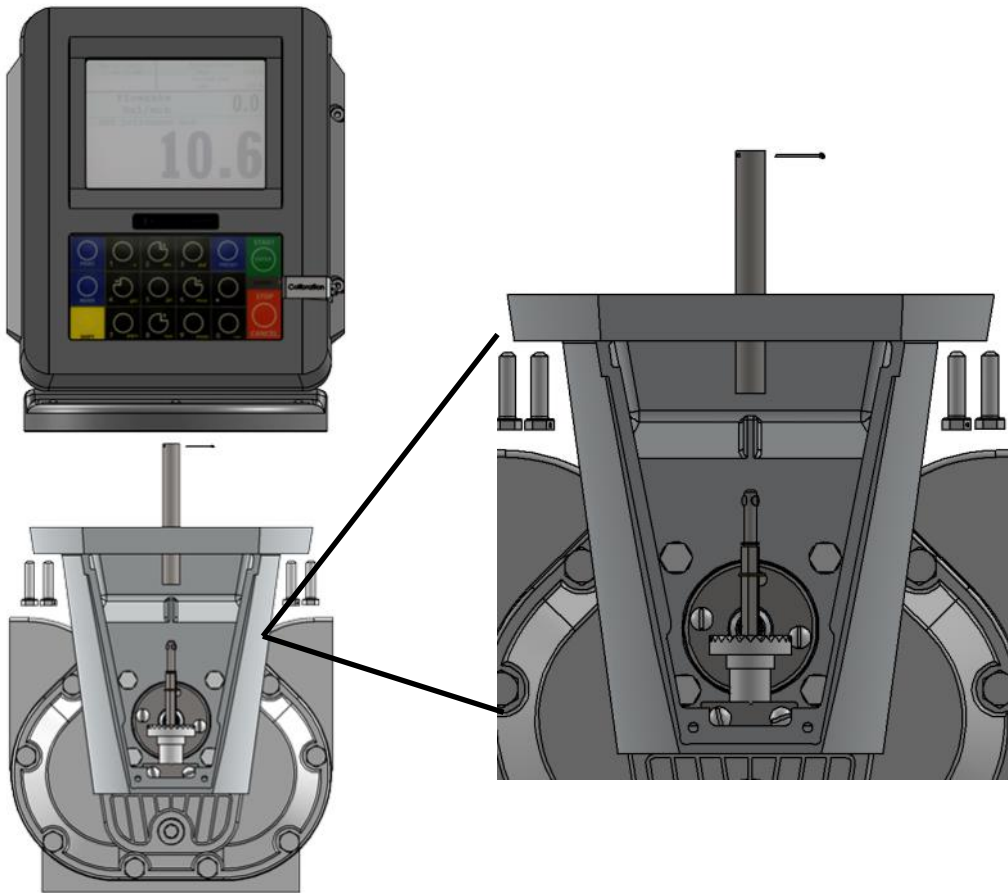

## Installation Procedure—TCS 682 Series Meter



Before beginning the installation of the TCS 3000, unpack the entire contents of the packaging in a safe location where you will not misplace any of the parts. Lay out the parts as they would be installed on the truck. This will ensure that you have all the correct parts for the installation. Verifying all the necessary parts were included in the shipment in advance will reduce the truck downtime and avoid any wasted truck preparation work.

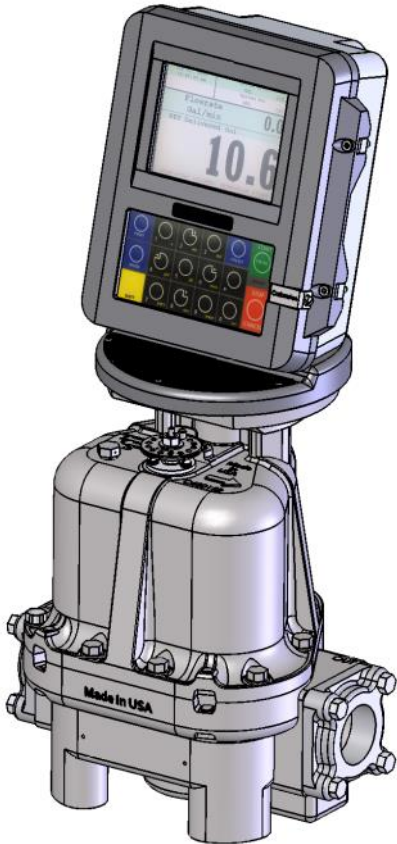

Item	Qty	TCS P/N
Phillips Pan MS M4X8	6	TCS300137
Spring Washer M4	6	TCS300138
Terminal Cover	1	TCS300164
3000 Reg. 7.5 AMP Fuse	1	TCS300192
3000 Reg. Fuse Holder	1	TCS300193
Cable Gland	4	TCS300249
O-Ring	4	TCS300250
USB Fem/Mini Male Cable	1	TCS300705
Resistor 1K OHM	2	TCS300753
Coupling 682 to LCR II	1	TCS600420
1/4—28 X 3/4 Zinc Bolt	2	TCS68004
1/4—28 X 3/4 Drilled Bolt	2	TCS68004D
Coupling, 682	1	TCS600420
1/4—28 X 1 Zinc Bolt	2	TCS68013
1/4—28 X 1 Zinc Drilled Bolt	2	TCS68013D
3/64 X 1 Cotter Pin	1	TCS790091

TCS 3000 to TCS 682 Meter Install Kit (TCS300871)

### Installation Procedure:

1. Remove and put aside the four mounting bolts and any mounting adaptor. Remove the existing mechanical register or electronic register, if applicable. Use a box or container to set old equipment and parts in.
2. Using the shaft specific to your installation, slide the Drive Shaft Adaptor on the Pulser Shaft and align the holes. Once the holes are aligned insert the Cotter Pin and bend the pin ends back around the Shaft Adaptor.
3. Slide the Adaptor onto the Meter Drive Shaft.
4. Rotate the TCS 3000 until the display is facing in the desired direction and check to see that the meter holes align with the holes at the base of the TCS 3000.
5. Secure the bolts.



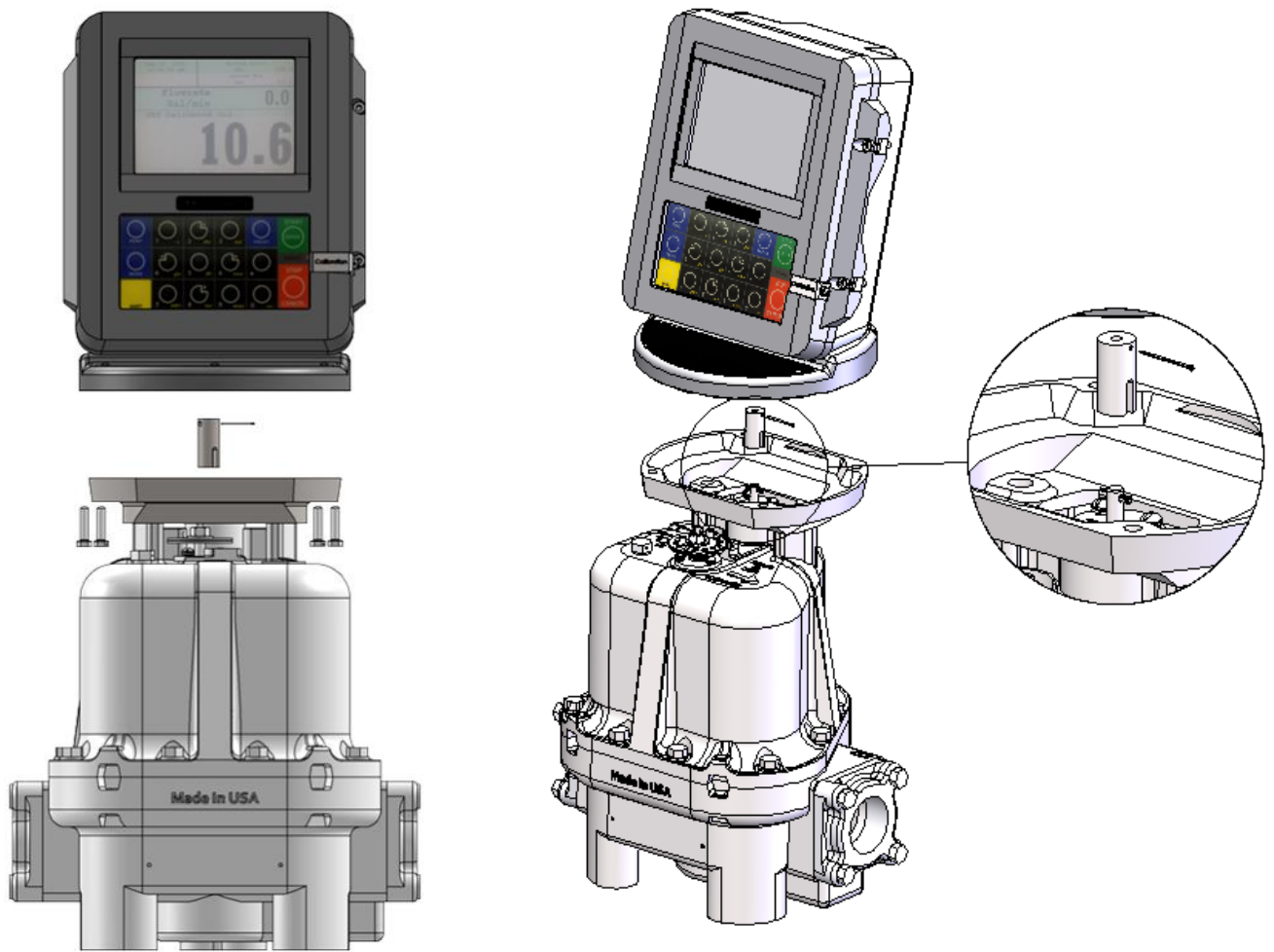

## Installation Procedure—3000 Remote Mount/Pulser



Before beginning the installation of the TCS 3000, unpack the entire contents of the packaging in a safe location where you will not misplace any of the parts. Lay out the parts as they would be installed on the truck. This will ensure that you have all the correct parts for the installation. Verifying all the necessary parts were included in the shipment in advance will reduce the truck downtime and avoid any wasted truck preparation work.

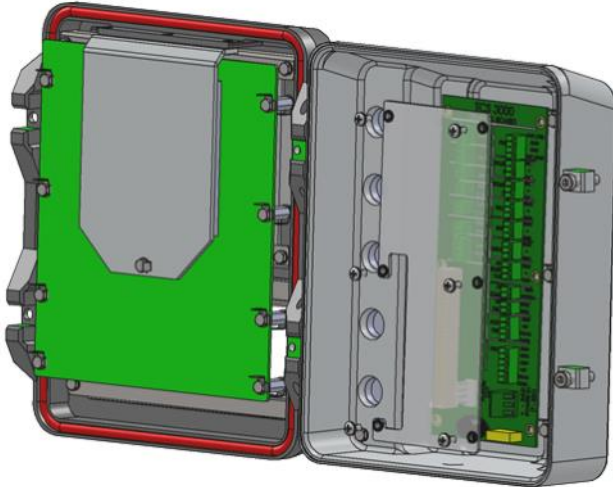

Item	Qty	TCS P/N Metric	TCS P/N NPT
Phillips Pan MS M4X8	6	TCS300137	
Spring Washer M4	6	TCS300138	
Terminal Cover	1	TCS300164	
3000 Reg. 7.5 AMP Fuse	1	TCS300192	
3000 Reg. Fuse Holder	1	TCS300193	
Cable Gland 1/2" NPT	4	TCS300249	
O-Ring	4	TCS300250	
USB Fem/Mini Male Cable	1	TCS300705	
Resistor 1K OHM	2	TCS300753	

TCS 3000 to Wall Mount Install Kit (TCS300877)



Item	Qty	TCS P/N
Pulser	1	TCS 300160
Pulser Nut 1/2—32 Hex	1	TCS 300162
Terminal Cover	1	TCS 300164
O-Ring –013 FKM	1	TCS 300166

TCS 3000 Pulser Kit (TCS 300866)

### Installation Procedure:

1. Use the wall mount kit to mount the TCS3000 in your desired location.
2. Follow the directions (TCS900030) to install the Pulser on the meter.
3. Once the Pulser is wired, run the corresponding wire cable into the back of the TCS 3000.
4. Insert the pulser wiring into the cable gland. Wire the pulser into the correct pulser location on the terminal board. Leave a small amount of slack on the wiring.
5. Compress the cable gland on the TCS3000 until it is snug on the pulser wire.

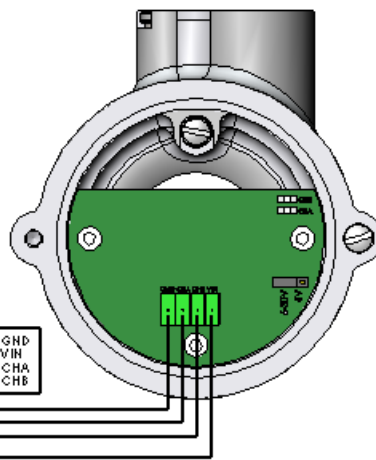
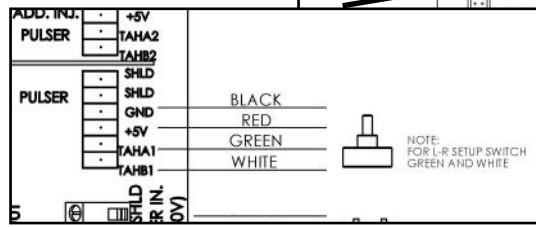
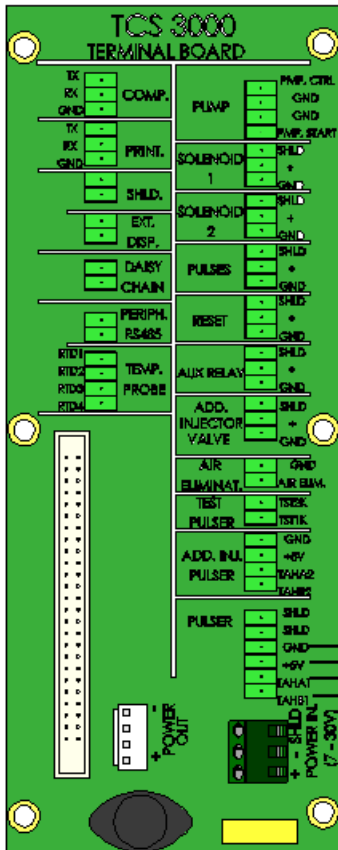
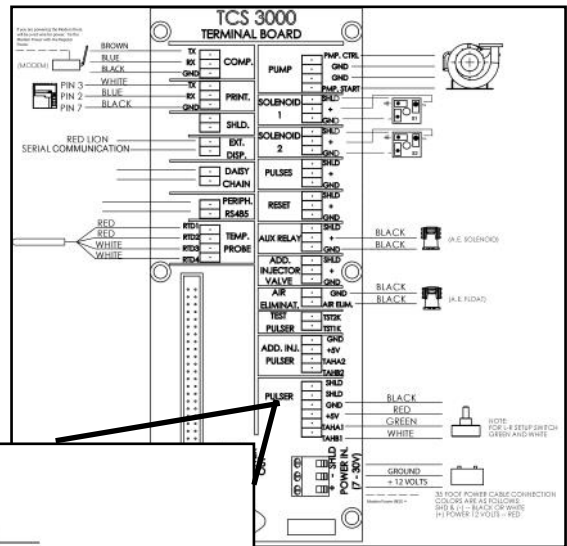
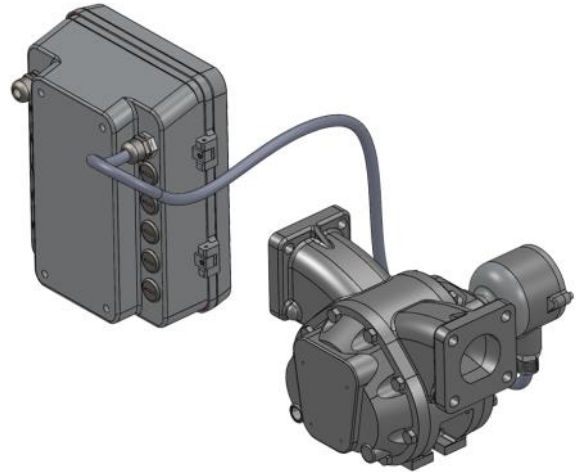
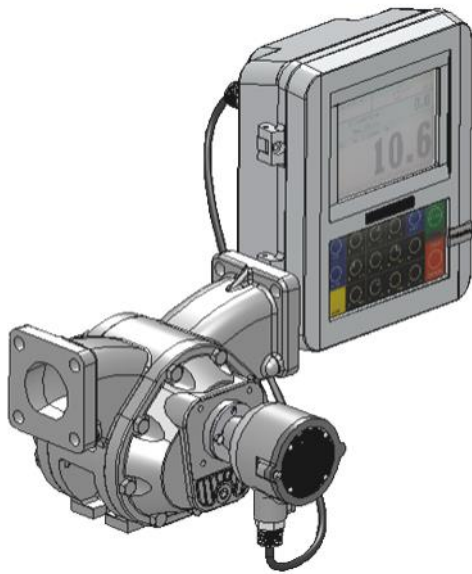

## Installation Procedure—Electronic Air Eliminator

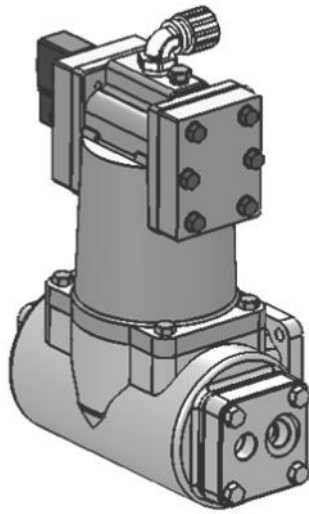

### Installation Procedure:

1. Locate the air eliminator float wiring in the metering system.
2. Screw the cable gland into the back of the TCS 3000 and tighten into the housing.
3. Run the air eliminator float wiring in the cable gland. Wire the air eliminator float into the correct location on the terminal board. Leave a small amount of slack on the wiring.
4. Compress the cable gland on the TCS3000 until it is snug on the air eliminator float wiring.

Air Eliminator Float Wiring

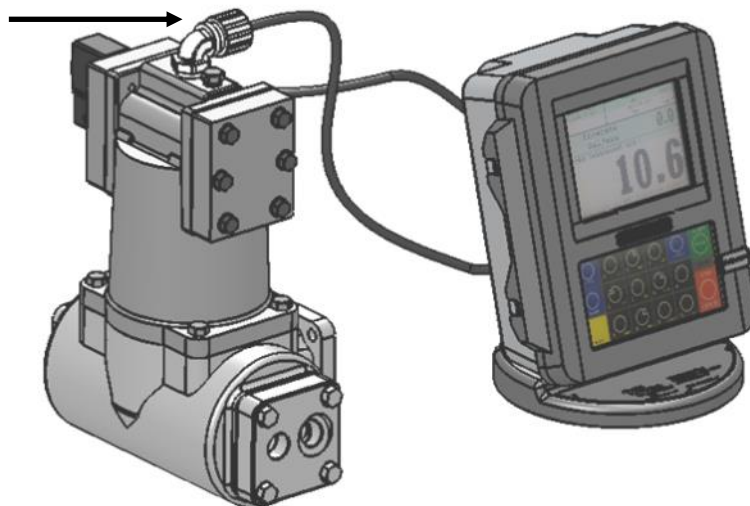

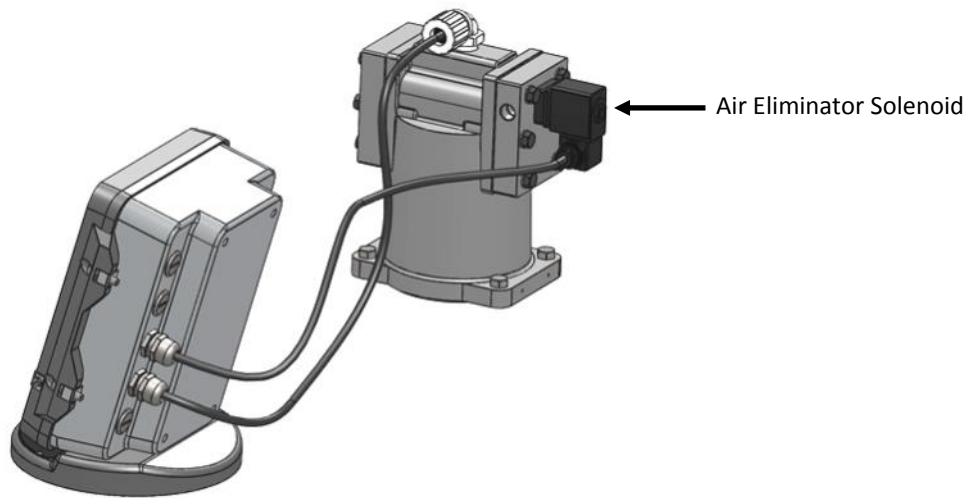

5. Locate the air eliminator solenoid wiring in the metering system.
6. Screw the cable gland into the back of the TCS 3000 and tighten into the housing.
7. Run the air eliminator solenoid wiring in the cable gland. Wire the air eliminator solenoid into the correct location on the terminal board. Leave a small amount of slack on the wiring.
8. Compress the cable gland on the TCS3000 until it is snug on the air eliminator solenoid wiring.

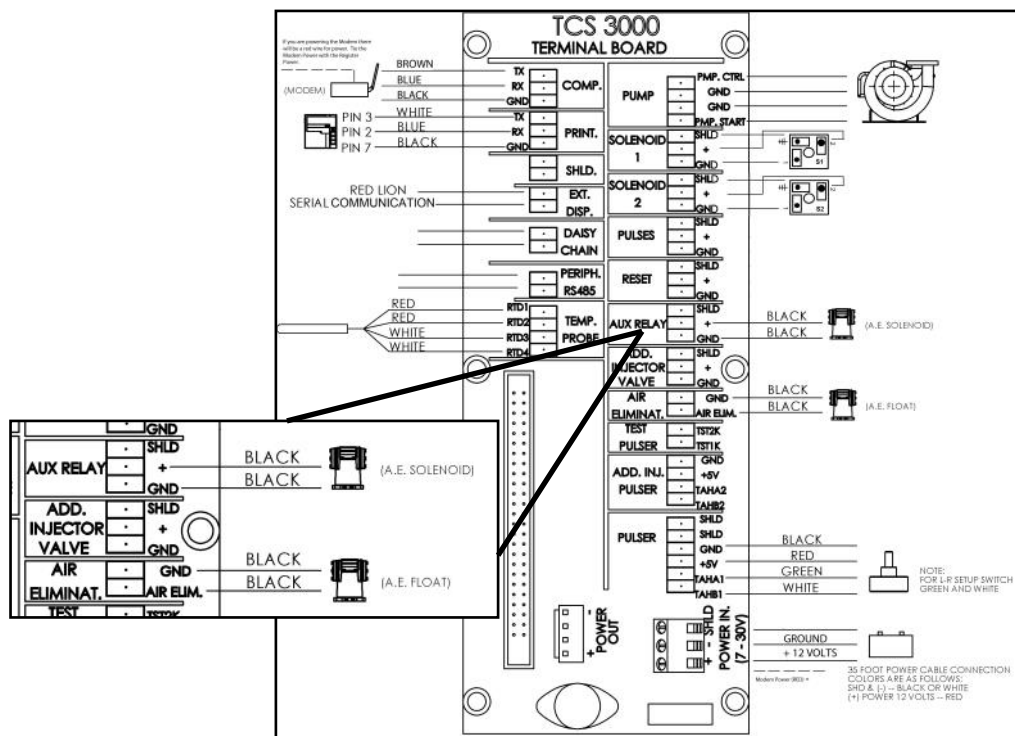

## Installation Procedure—3-Way LPG Valve

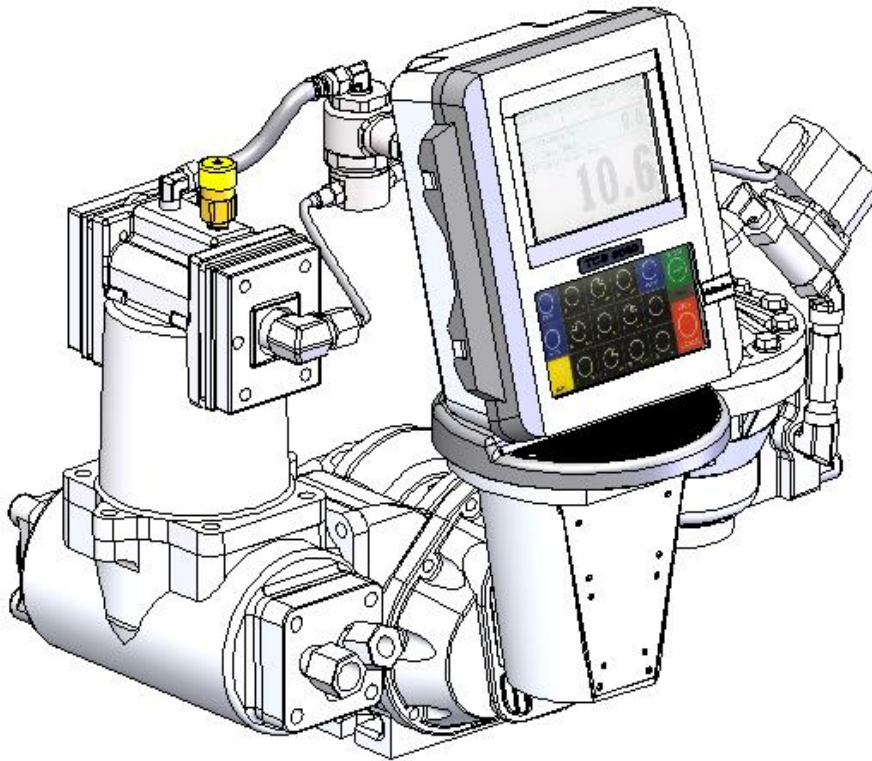

### Installation Procedure:

1. Using the bolts and gasket provided, install the valve on the outlet side of the meter.
2. Follow the instructions provided with the valve (TCS ) for wiring the solenoid.
3. Mount the 3 Way Valve directly to the TCS3000 and follow the instructions provided with the Valve.  
**\*Note: Use Correct Thread Sealant\***
4. Once the solenoid is wired, run the corresponding wire as pictured using a minimum of 22gauge shielded cable into the back of the TCS 3000.
5. Insert the solenoid wiring into the cable gland. Wire the solenoid into the correct solenoid location on the terminal board. Leave a small amount of slack on the wiring.
6. Compress the cable gland on the TCS3000 until it is snug on the solenoid wire.

**\*When Calibrating the Unit Set Up Valve Type as 1001\***

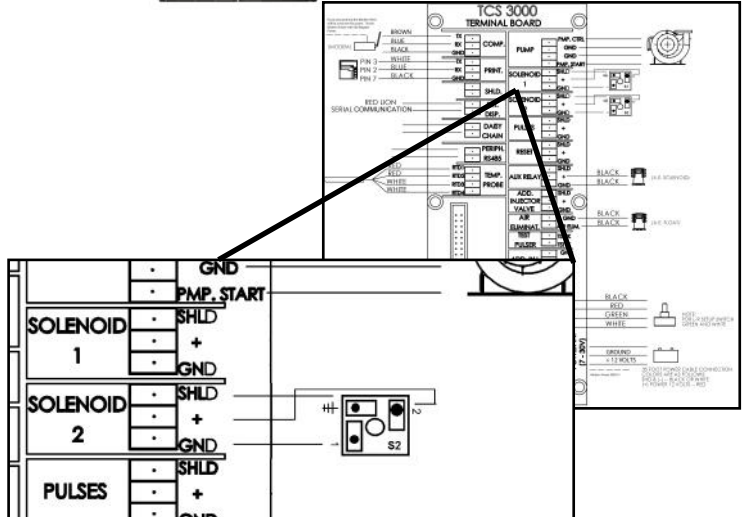
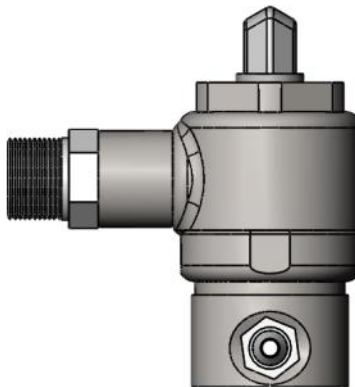
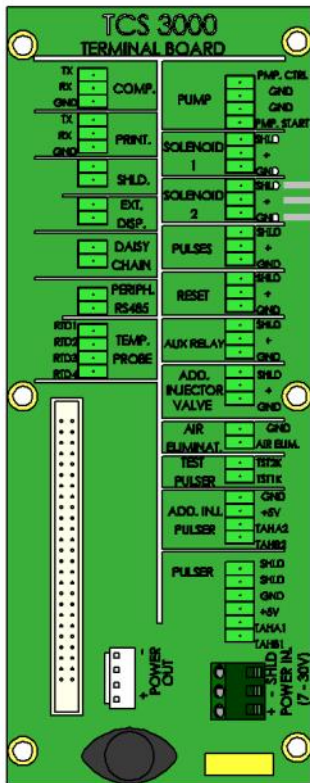
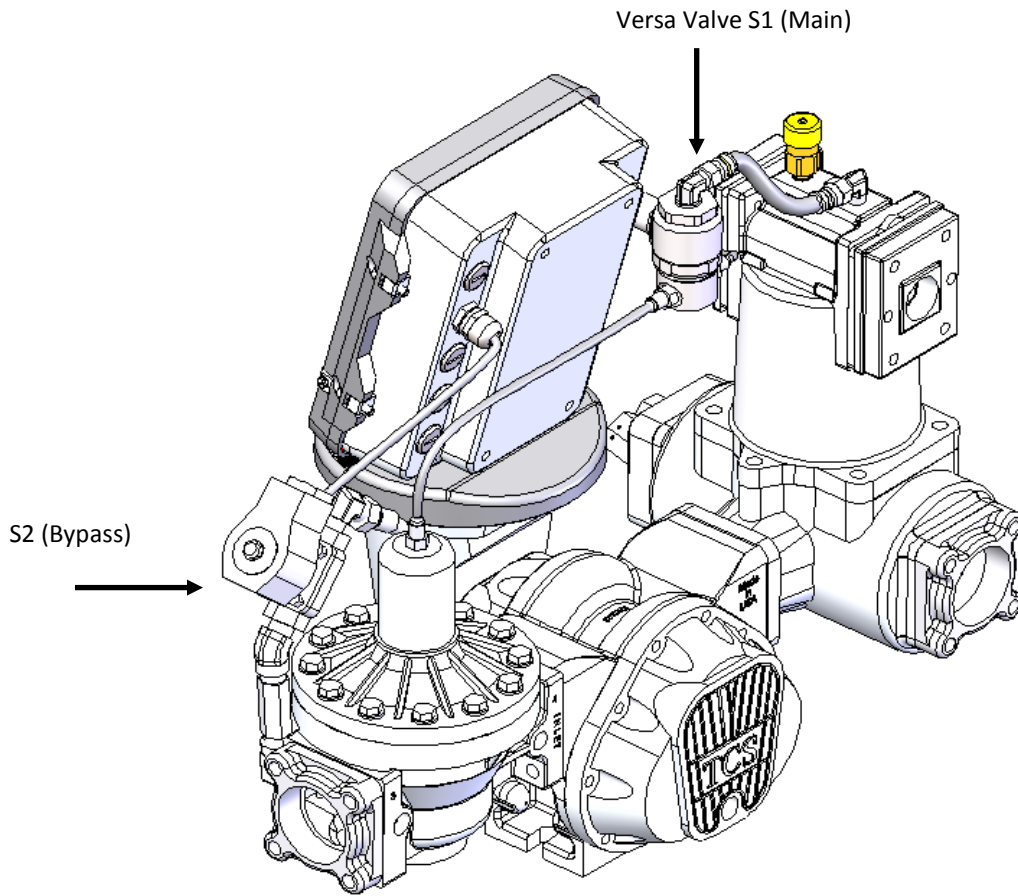

# Installation Procedure—655-21 Single Stage Valve

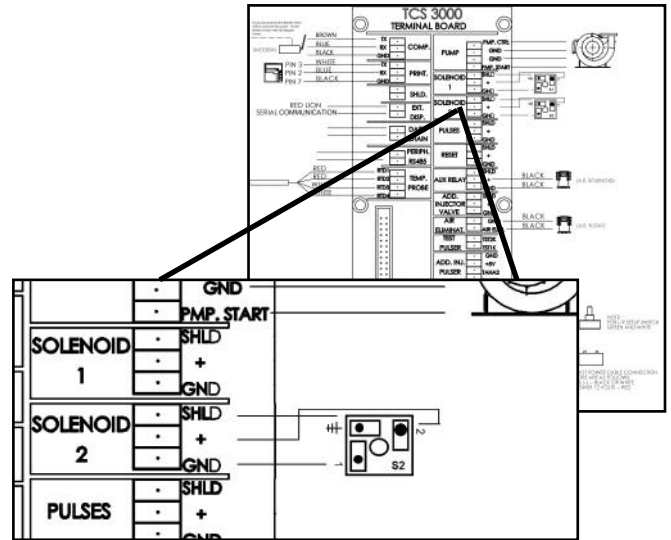
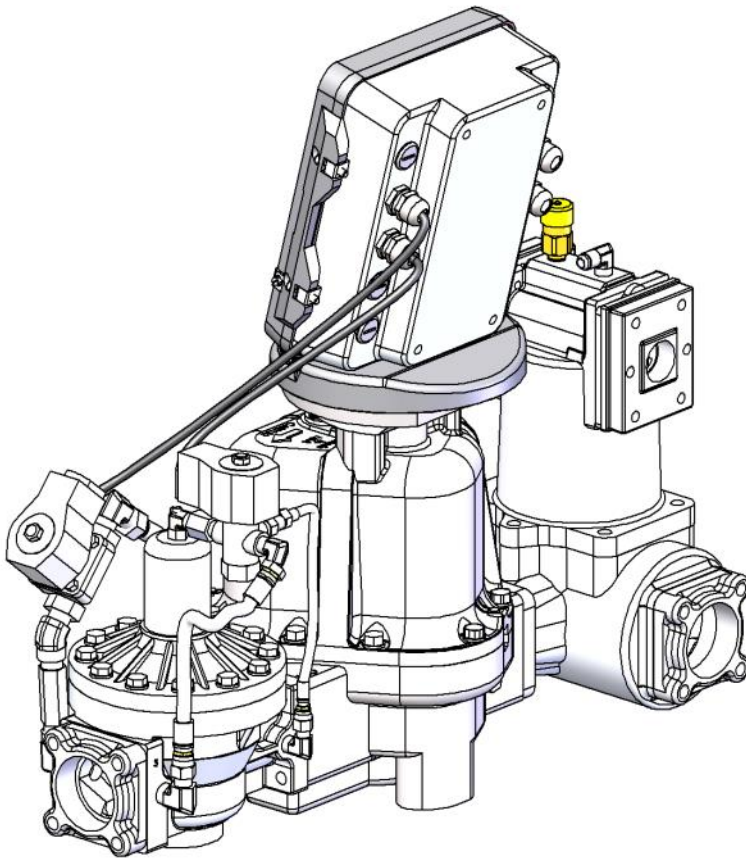

## Installation Procedure:

1. Using the bolts and gasket provided, install the valve on the outlet side of the meter.
2. Follow the instructions provided with the valve (TCS 9000051) for wiring the solenoid.
3. Once the solenoid is wired, run the corresponding wire as pictured using a minimum of 22gauge shielded cable into the back of the TCS 3000.
4. Insert the solenoid wiring into the cable gland. Wire the solenoid into the correct solenoid location on the terminal board. Leave a small amount of slack on the wiring.
5. Compress the cable gland on the TCS3000 until it is snug on the solenoid wire.



## Installation Procedure—755-21 Single Stage Valve

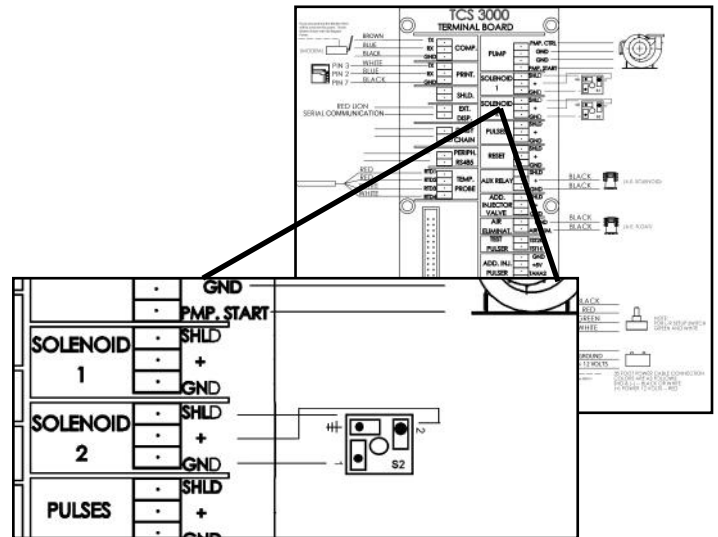
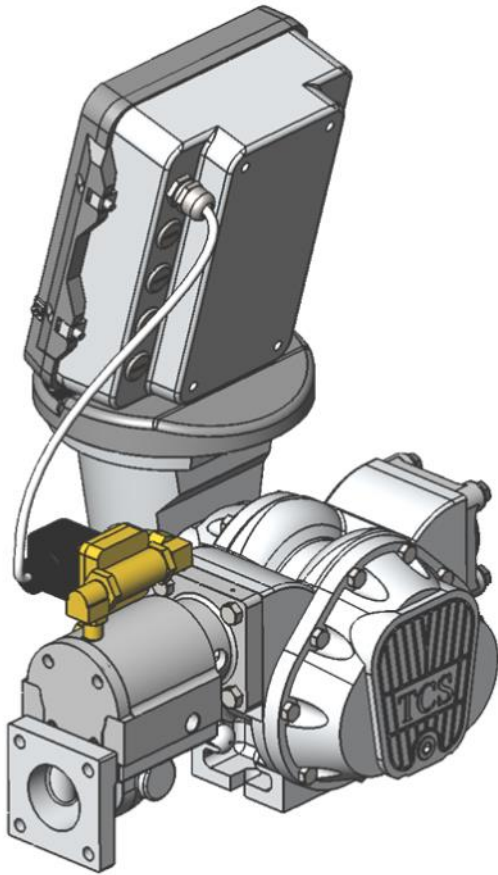

### Installation Procedure:

1. Using the bolts and gasket provided, install the valve on the outlet side of the meter.
2. Follow the instructions provided with the valve (TCS 9000051) for wiring the solenoid.
3. Once the solenoid is wired, run the corresponding wire as pictured using a minimum of 22gauge shielded cable into the back of the TCS 3000.
4. Insert the solenoid wiring into the cable gland. Wire the solenoid into the correct solenoid location on the terminal board. Leave a small amount of slack on the wiring.
5. Compress the cable gland on the TCS3000 until it is snug on the solenoid wire.

# Installation Procedure—755-31 Single Stage Valve

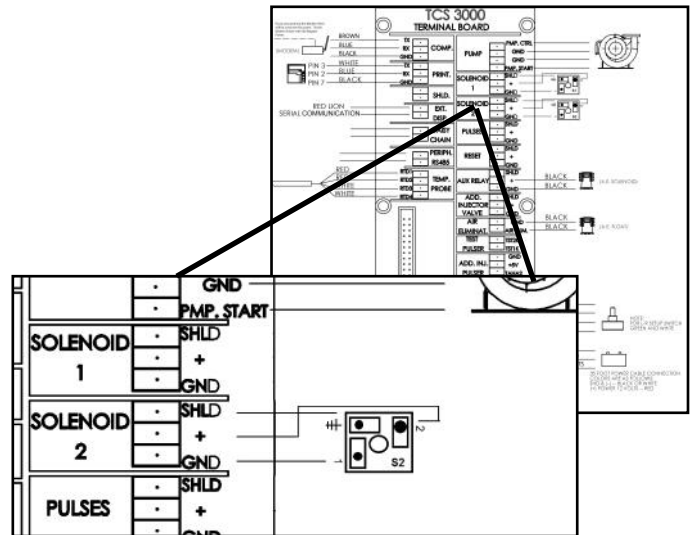
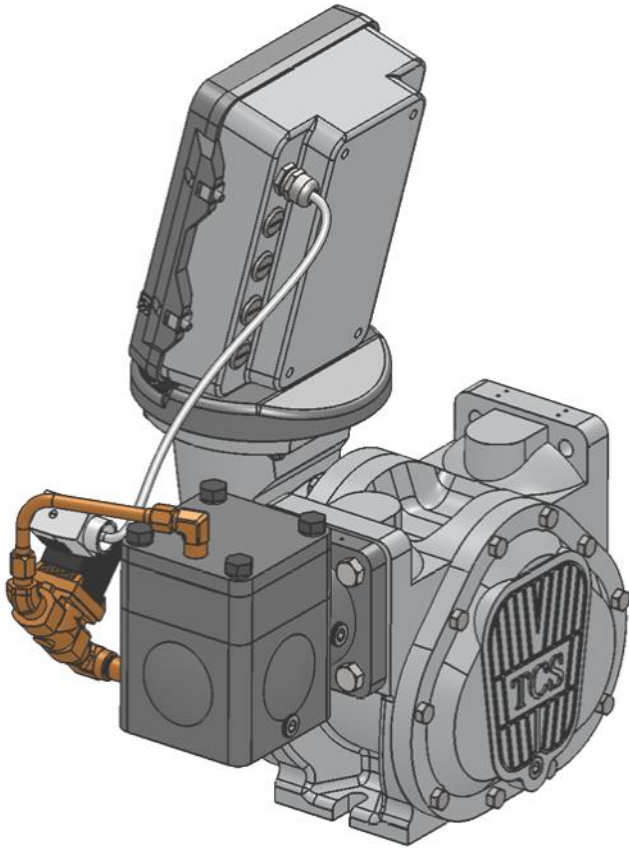

## Installation Procedure:

1. Using the bolts and gasket provided, install the valve on the outlet side of the meter.
2. Follow the instructions provided with the valve (TCS 9000051) for wiring the solenoid.
3. Once the solenoid is wired, run the corresponding wire as pictured using a minimum of 22gauge shielded cable into the back of the TCS 3000.
4. Insert the solenoid wiring into the cable gland. Wire the solenoid into the correct solenoid location on the terminal board. Leave a small amount of slack on the wiring.
5. Compress the cable gland on the TCS3000 until it is snug on the solenoid wire.

## Installation Procedure—755-20 2-Stage Valve

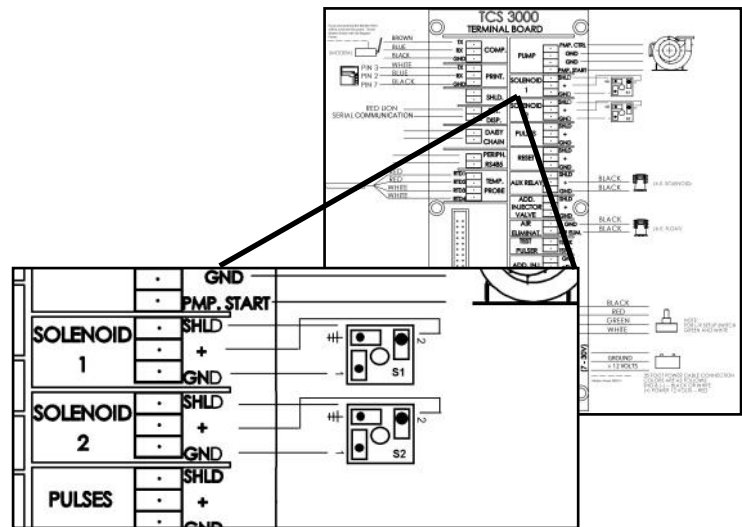
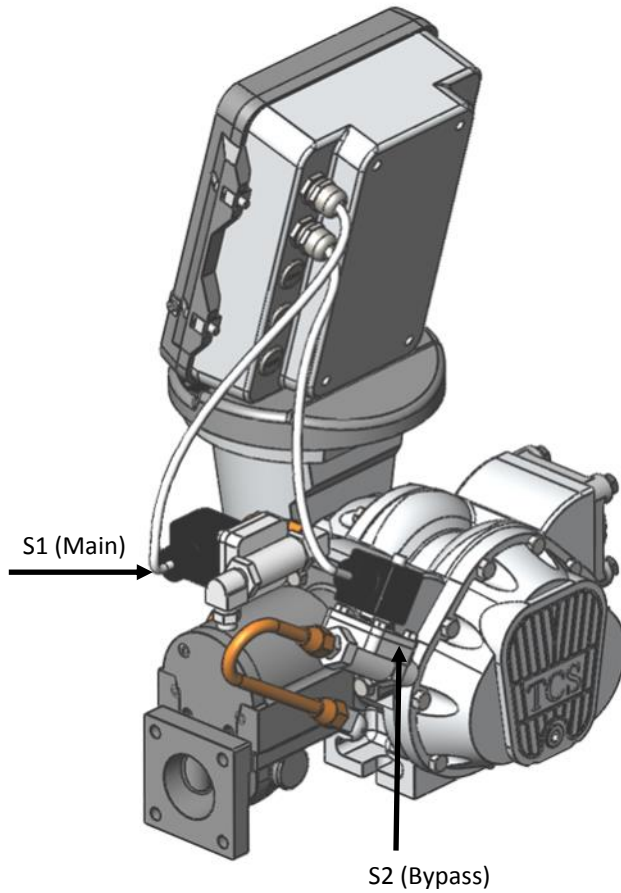

### Installation Procedure:

1. Using the bolts and gasket provided, install the valve on the outlet side of the meter.
2. Follow the instructions provided with the valve (TCS 9000051) for wiring the solenoid.
3. Once the solenoid is wired, run the corresponding wire as pictured using a minimum of 22gauge shielded cable into the back of the TCS 3000.
4. Insert the solenoid wiring into the cable gland. Wire the solenoid into the correct solenoid location on the terminal board. Leave a small amount of slack on the wiring.
5. Compress the cable gland on the TCS3000 until it is snug on the solenoid wire.

\*When Calibrating the Unit Set Up Valve Type as 1101\*

# Installation Procedure—755-30 2-Stage Valve

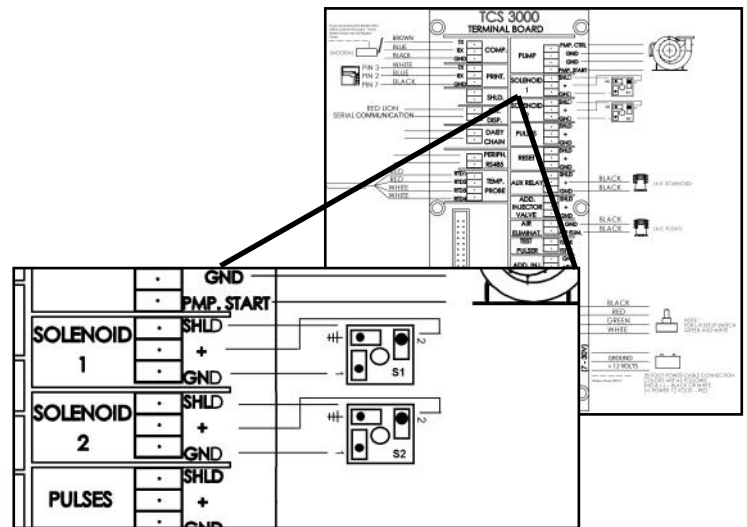
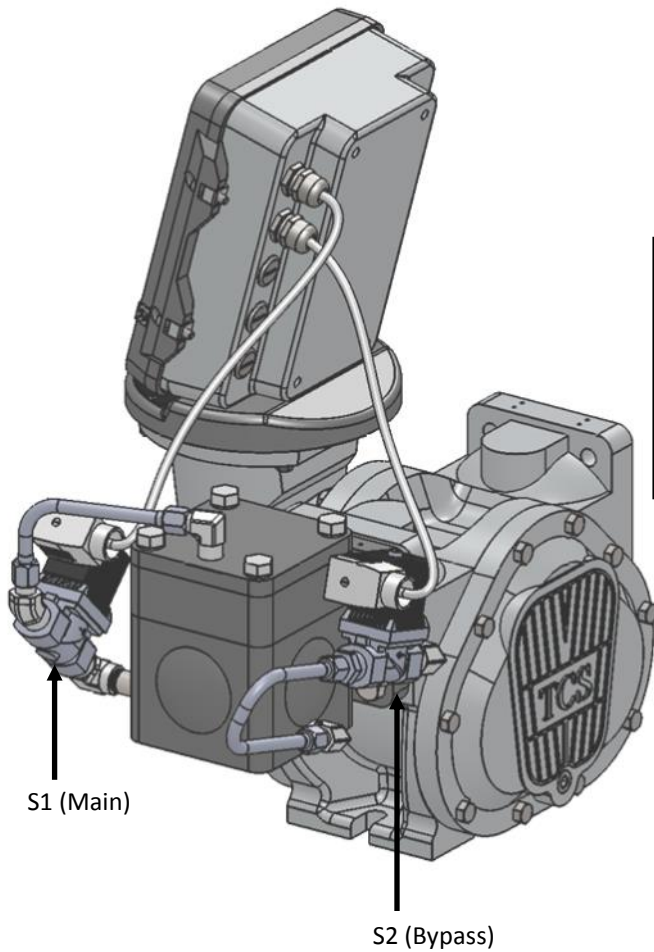

## Installation Procedure:

1. Using the bolts and gasket provided, install the valve on the outlet side of the meter.
2. Follow the instructions provided with the valve (TCS 9000051) for wiring the solenoid.
3. Once the solenoid is wired, run the corresponding wire as pictured using a minimum of 22gauge shielded cable into the back of the TCS 3000.
4. Insert the solenoid wiring into the cable gland. Wire the solenoid into the correct solenoid location on the terminal board. Leave a small amount of slack on the wiring.
5. Compress the cable gland on the TCS3000 until it is snug on the solenoid wire.

\*When Calibrating the Unit Set Up Valve Type as 1101\*

Installation Procedure—Vibronic Sensor

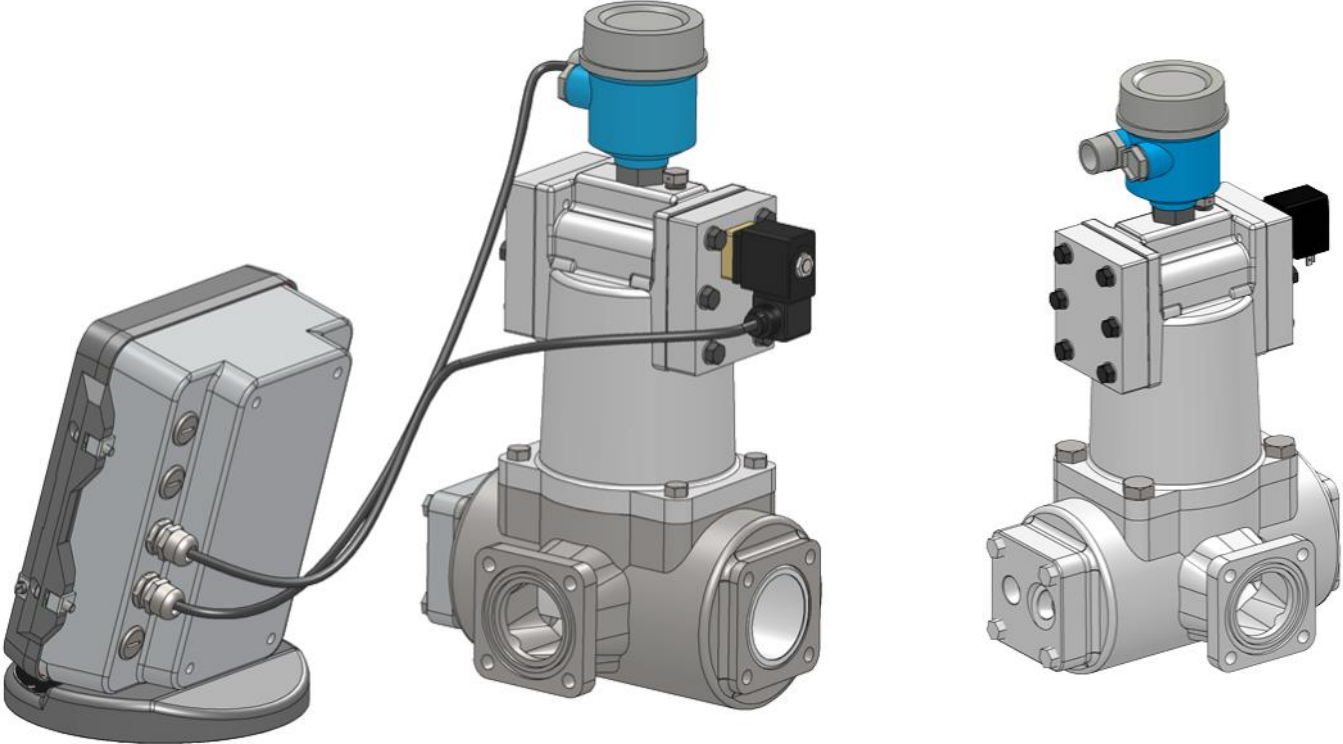

Installation Procedure:

Instructions to follow.

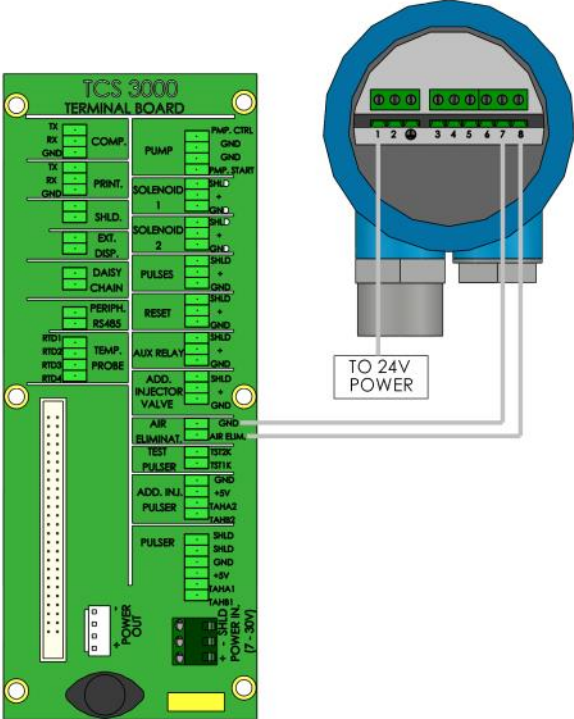

## Installation Procedure—Timing Relay



### Timing Relay

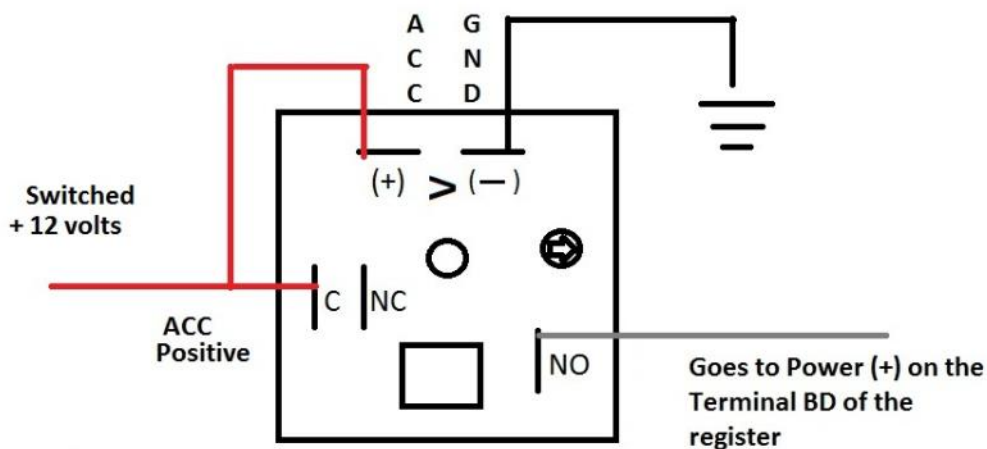

#### Wiring Instruction:

1. Wire GND to Chassis Ground or the negative side of the Battery. \*Note needs to be a good ground!
2. Wire ACC (+) to (C) ACC Positive (on the relay) then ACC Positive to the truck ACC (ignition).
3. Wire N.O. to the (Positive) side Power Cable coming from the Terminal BD into the cab of the truck, if you are using Quick Disconnect this would be (Red/White) or Positive side of the Power Cable to the Register.

\*Note: If your wiring a Printer and a Handheld Power Supply they should be wired to N.O also. This will allow them to all power-up at the same time.

## Installation Procedure—Temperature Probe

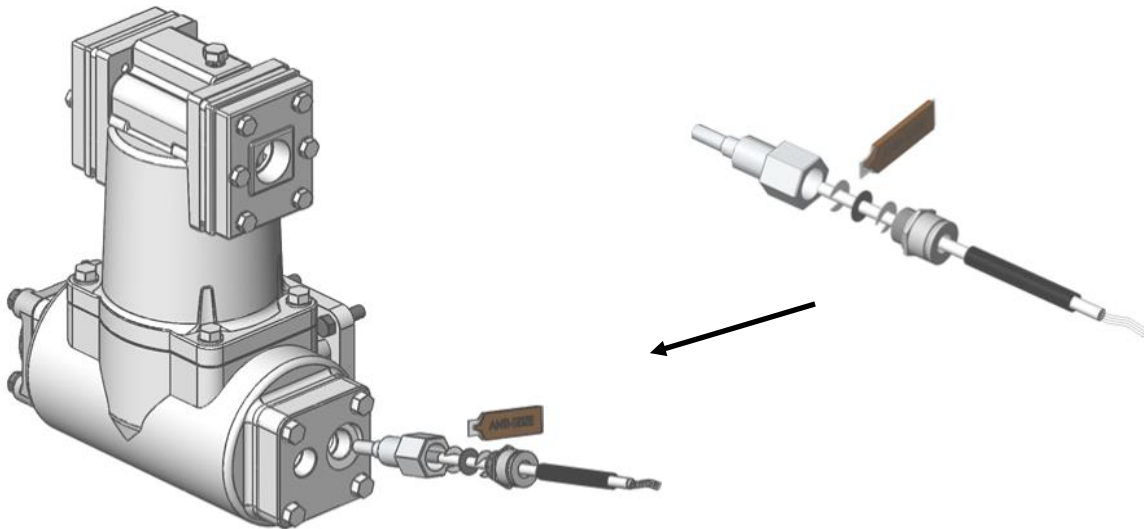

### Installation Procedure:

1. Locate the thermowell in the metering system.
2. Slide the temperature probe jacket over the temperature probe wire until it covers the entire wire.
3. Screw the cable gland into the thermowell and tighten. Squeeze the Copper Anti Sieze on the metal tip of the temperature probe.
4. Slide the temperature probe into the thermowell. Compress the cable gland down onto the temperature probe.
5. Screw the cable gland into the back of the TCS3000 and tighten.
6. Insert the temperature probe wiring into the cable gland. Wire the Temp. Probe into the Temp Probe location on the terminal board. Leave a small amount of slack on the wiring.
7. Compress the cable gland on the TCS3000 until it is snug on the temperature probe wire.

## Installation Procedure—Temperature Probe Cont.



8. Run the temperature probe wiring to the back of the TCS 3000. Insert the wiring into the third cable gland from the top of the register as pictured on page 18.
9. Leave slack in the temperature probe wiring and tighten the cable gland down on the temperature probe. If Needed the probe wire may be trimmed of excess wire before tightening down the cable gland.
10. Wire the probe into the TCS 3000 as pictured.

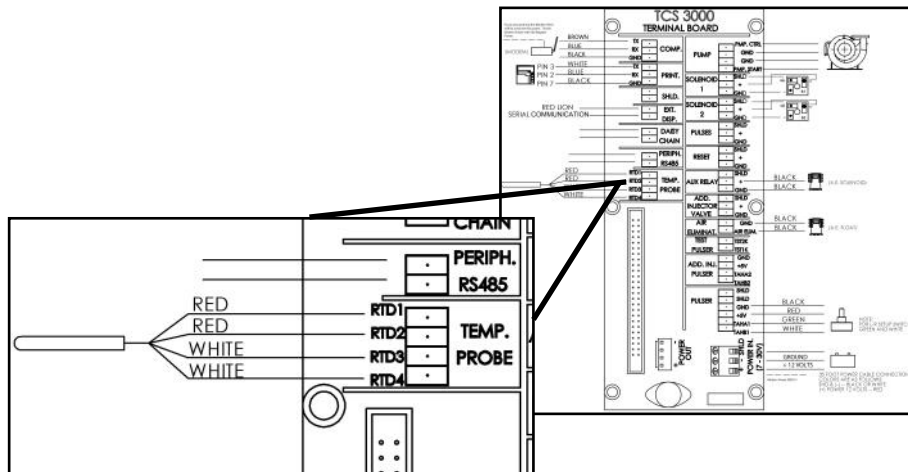
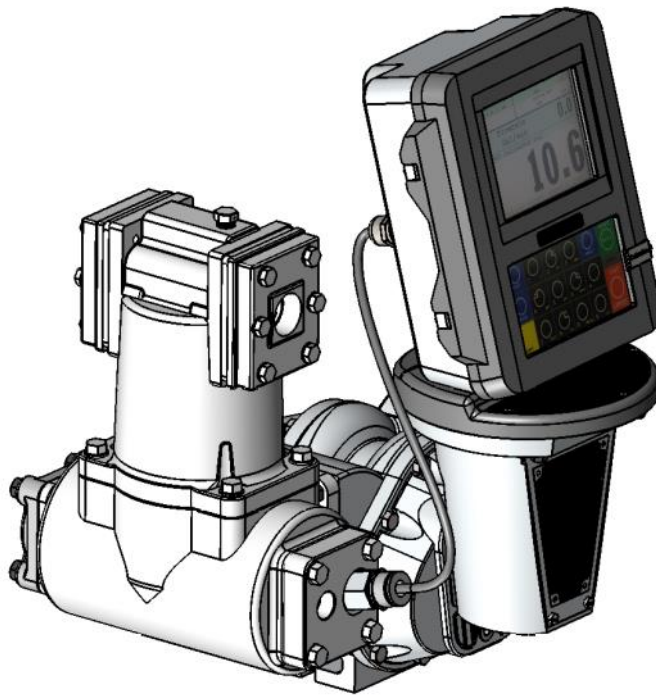



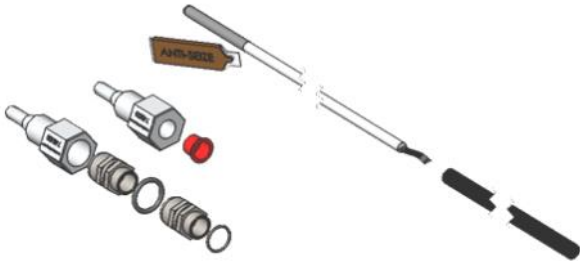

Item	Qty	TCS P/N
Cable Gland M20X1.5 UL	1	TCS 300244
O-Ring Buna M20 Gland	1	TCS 300245
Cable Gland, 1/2 MPT UL	1	TCS 300254
O-Ring, 1/2NPT Gland	1	TCS 300255
4 Wire Temp Probe SS En	1	TCS 300701
Temperature Probe Jacket	1	TCS 300702
Capplug T6X	1	TCS 300719
Copper Antiseize 2 Gram	1	TCS 300749
Thermowell 1/2" Stainless	1	TCS 740400
Thermowell 3/8" Stainless	1	TCS 740405

TCS 3000 RTD Probe/SS Thermowell Kit (TCS 300815)



Item	Qty	TCS P/N
Cable Gland M20X1.5 UL	1	TCS 300244
O-Ring Buna M20 Gland	1	TCS 300245
Cable Gland, 1/2 MPT UL	1	TCS 300254
O-Ring, 1/2NPT Gland	1	TCS 300255
4 Wire Temp Probe SS En	1	TCS 300701
Temperature Probe Jacket	1	TCS 300702
Capplug T6X	1	TCS 300719
Copper Antiseize 2 Gram	1	TCS 300749

TCS 3000 RTD Probe Only Kit (TCS 300880)



Item	Qty	TCS P/N
Cable Gland M20X1.5 UL	1	TCS 300244
O-Ring Buna M20 Gland	1	TCS 300245
Cable Gland, 1/2 MPT UL	1	TCS 300254
O-Ring, 1/2NPT Gland	1	TCS 300255
4 Wire Temp Probe SS En	1	TCS 300701
Temperature Probe Jacket	1	TCS 300702
Capplug T6X	1	TCS 300719
Copper Antiseize 2 Gram	1	TCS 300749
Thermowell 1/2" Aluminum	1	TCS 740300
Thermowell 3/8" Aluminum	1	TCS 740305

# Installation Procedure—Printer

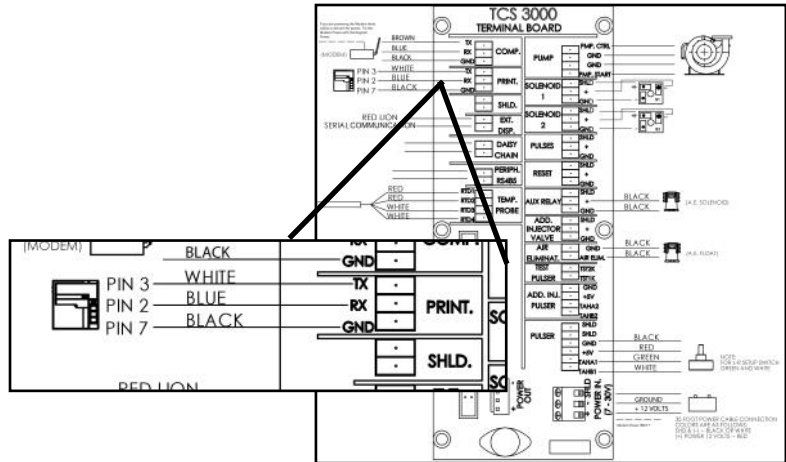
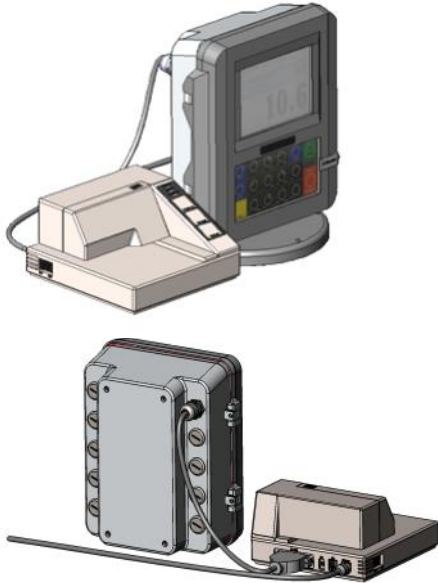

## Installation Procedure:

1. Find a suitable location for the printer appropriate to your application.
2. Secure the printer in place with the Velcro strip provided.
3. Wire the power and communication cables into the back of the printer.
4. Run the communication cable to the back of the TCS3000.
5. Screw the cable gland into the back of the TCS3000 and tighten.
6. Insert the printer communication cable into the cable gland and wire into the correct location on the terminal board.
7. Compress the cable gland on the TCS3000 until it is snug on the printer communication cable.

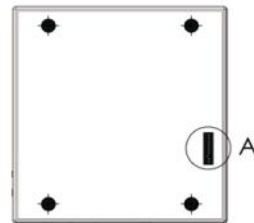

The DIP Switch on Pole 3 must be set to ON.

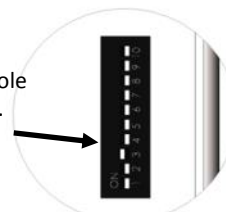

DETAIL A

**NOTE: Once DIP Switch 3 has been moved to position ON; You must cycle power for the Parameter to retain.**

## TCS 3000 Epson Slip 12 VDC Kit (Metric TCS 300851 / NPT TCS 300951)



Item	Qty	Metric TCS P/N	NPT TCS P/N
Cable Gland M20X1.5 UL	1	TCS 300244	-
O-Ring, Buna M20 Glad	1	TCS 300245	-
O-Ring, 1/2" NPT Gland	1	-	TCS 300255
12VDC Epson Printer Power	1	TCS 300712	TCS 300712
3 Wire Printer Comm Cable	1	TCS 300714	TCS 300714
Velcro 4" X 5"	1	TCS 300721	TCS 300721
Epson Printer	1	TEL TMU295-011	TEL TMU295-011
Wehof Order Form	1	TCS WEHOF	TCS WEHOF

## TCS 3000 Epson Slip 24 VDC Print Kit (Metric TCS 300885 / NPT TCS 300985)



Item	Qty	Metric TCS P/N	NPT TCS P/N
Cable Gland M20X1.5 UL	1	TCS 300244	-
O-Ring, Buna M20 Glad	1	TCS 300245	-
O-Ring, 1/2" NPT Gland	1	-	TCS 300255
3 Wire Printer Comm Cable	1	TCS 300714	TCS 300714
Velcro 4" X 5"	1	TCS 300721	TCS 300721
Epson Printer	1	TEL TMU295-011	TEL TMU295-011
24 VDC Epson Printer Power	1	TCS 300772	TCS 300772
Wehof Order Form	1	TCS WEHOF	TCS WEHOF

## TCS 3000 Epson Slip Print 110V Kit (Metric TCS 300869 / NPT TCS 300969)



Item	Qty	Metric TCS P/N	NPT TCS P/N
Cable Gland M20X1.5 UL	1	TCS 300244	-
O-Ring, Buna M20 Glad	1	TCS 300245	-
Cable Gland, 1/2 NPT UL	1	-	TCS 300254
O-Ring, 1/2 NPT Gland	1	-	TCS 300255
3 Wire Printer Comm. Cable	1	TCS 300714	TCS 300714
Velcro 4" X 5"	1	TCS 300721	TCS 300721
Epson Printer	1	TEL TMU295-011	TEL TMU295-011
AC Power Supply w Cord	1	TEL TPS-180	TEL TPS-180
Wehof Order Form	1	TCS WEHOF	TCS WEHOF

### TCS 3000 Epson Roll 12 VDC Kit (Metric TCS 300850 / NPT TCS 300950)

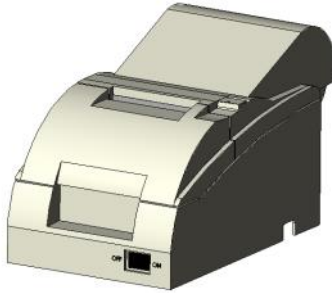

Item	Qty	Metric TCS P/N	NPT TCS P/N
Cable Gland M20X1.5 UL	1	TCS 300244	-
O-Ring, Buna M20 Glad	1	TCS 300245	-
Cable Gland, 1/2 NPT Gland	1	-	TCS 300254
O-Ring, 1/2 NPT Gland	1	-	TCS 300255
12 VDC Epson Printer Power	1	TCS 300712	TCS 300712
3 Wire Printer Comm. Cable	1	TCS 300714	TCS 300714
Velcro 4" X 5"	1	TCS 300721	TCS 300721
Roll Printer	1	TEL TMU220A103	TEL TMU220A103
Wehof Order Form	1	TCS WEHOF	TCS WEHOF

### TCS 3000 Epson Roll 24 VDC Print Kit (Metric TCS 300884 / NPT TCS 300984)



Item	Qty	Metric TCS P/N	NPT TCS P/N
Cable Gland M20X1.5 UL	1	TCS 300244	-
O-Ring, Buna M20 Glad	1	TCS 300245	-
Cable Gland, 1/2 NPT Gland	1	-	TCS 300254
O-Ring, 1/2 NPT Gland	1	-	TCS 300255
3 Wire Printer Comm Cable	1	TCS 300714	TCS 300714
Velcro 4" X 5"	1	TCS 300721	TCS 300721
24 VDC Epson Printer Power	1	TCS 300772	TCS 300772
Roll Printer	1	TEL TMU220A103	TEL TMU220A103
Wehof Order Form	1	TCS WEHOF	TCS WEHOF

### TCS 3000 Epson Roll 110 VAC Print Kit (Metric TCS 300886 / NPT 300986)

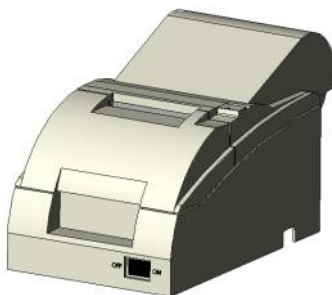

Item	Qty	Metric TCS P/N	NPT TCS P/N
Cable Gland M20X1.5 UL	1	TCS 300244	-
O-Ring, Buna M20 Glad	1	TCS 300245	-
Cable Gland, 1/2 NPT Gland	1	-	TCS 300254
O-Ring, 1/2 NPT Gland	1	-	TCS 300255
3 Wire Printer Comm Cable	1	TCS 300714	TCS 300714
Velcro 4" X 5"	1	TCS 300721	TCS 300721
Roll Printer	1	TEL TMU220A103	TEL TMU220A103
110VAC Epson Printer Power	1	TCS 300773	TCS 300773
Wehof Order Form	1	TCS WEHOF	TCS WEHOF

**\* TCS 3000 Printek Bluetooth Kit (Metric TCS 300852 / NPT TCS 300952)**



Item	Qty	Metric TCS P/N	NPT TCS P/N
Cable Gland M20X1.5 UL	1	TCS 300244	-
O-Ring Buna M20 Gland	1	TCS 300245	-
Cable Gland, 1/2 NPT UL	1	-	TCS 300254
O-Ring, 1/2 NPT Gland	1	-	TCS 300255
Printek Printer	1	TCS 300706	TCS 300706
Velcro 4" X 5"	1	TCS 300721	TCS 300721
Bluetooth Modem	1	TCS 300722	TCS 300722
Printek Charger	1	TCS 300727	TCS 300727
Printek Blue Tooth Docking	1	TCS 300728	TCS 300728
Wehof Order Form	1	TCS WEHOF	TCS WEHOF

**\* TCS 3000 Printek Bluetooth Kit (Metric TCS 300853 / NPT TCS 300953)**



Item	Qty	Metric TCS P/N	NPT TCS P/N
Cable Gland M20X1.5 UL	1	TCS 300244	-
O-Ring Buna M20 Gland	1	TCS 300245	-
Cable Gland, 1/2 NPT UL	1	-	TCS 300254
O-Ring, 1/2 NPT Gland	1	-	TCS 300255
Printek Printer	1	TCS 300706	TCS 300706
Velcro 4" X 5"	1	TCS 300721	TCS 300721
Bluetooth Modem	1	TCS 300722	TCS 300722
Printek Charger	1	TCS 300727	TCS 300727
Printek Blue Tooth Docking	1	TCS 300728	TCS 300728
Wehof Order Form	1	TCS WEHOF	TCS WEHOF

**\* TCS 3000 Citizen Bluetooth Kit (Metric TCS 300854 / NPT TCS 300954)**



Item	Qty	Metric TCS P/N	NPT TCS P/N
Cable Gland M20X1.5 UL	1	TCS 300244	-
O-Ring Buna M20 Gland	1	TCS 300245	-
Cable Gland, 1/2 NPT UL	1	-	TCS 300254
O-Ring, 1/2 NPT Gland	1	-	TCS 300255
Velcro 4" X 5"	1	TCS 300721	TCS 300721
Bluetooth Modem	1	TCS 300722	TCS 300722
Citizen Bluetooth Print	1	TCS 300723	TCS 300723
DC Truck Adapter/Citize	1	TCS 300724	TCS 300724
Wehof Order Form	1	TCS WEHOF	TCS WEHOF

\*Bluetooth Modem will not pair with other devices, unless TCS Programs the device at the Factory\*

### TCS 3000 Citizen Wifi Kit (Metric TCS 300855 / NPT TCS 300955)



Item	Qty	Metric TCS P/N	NPT TCS P/N
Cable Gland M20X1.5 UL	1	TCS 300244	-
O-Ring Buna M20 Gland	1	TCS 300245	-
Cable Gland, 1/2 NPT Gland	1	-	TCS 300254
O-Ring, 1/2 NPT Gland	1	-	TCS 300255
Velcro 4" X 5"	1	TCS 300721	TCS 300721
Bluetooth Modem	1	TCS 300722	TCS 300722
DC Truck Adapter/Citize	1	TCS 300724	TCS 300724
Citizen Wifi Printer CM	1	TCS 300750	TCS 300750
Wehof Order Form	1	TCS WEHOF	TCS WEHOF

### TCS 3000 Epson Slip 12V QD Print Kit (Metric TCS 300891 / NPT TCS 300991)



Item	Qty	Metric TCS P/N	NPT TCS P/N
Cable Gland M20X1.5 UL	1	TCS 300244	-
O-Ring, Buna M20 Glad	1	TCS 300245	-
Cable Gland, 1/2 NPT Gland	1	-	TCS 300254
O-Ring, 1/2 NPT Gland	1	-	TCS 300255
12VDC Epson Printer Power	1	TCS 300712	TCS 300712
Velcro 4" X 5"	1	TCS 300721	TCS 300721
Epson Printer	1	TEL TMU295-011	TEL TMU295-011
Wehof Order Form	1	TCS WEHOF	TCS WEHOF

### TCS 3000 Epson Slip 24V QD Print Kit (Metric TCS 300895 / NPT TCS 300995)



Item	Qty	Metric TCS P/N	NPT TCS P/N
Cable Gland M20X1.5 UL	1	TCS 300244	-
O-Ring, Buna M20 Glad	1	TCS 300245	-
Cable Gland, 1/2 NPT Gland	1	-	TCS 300254
O-Ring, 1/2 NPT Gland	1	-	TCS 300255
3 Wire Printer Comm Cable	1	TCS 300714	TCS 300714
Velcro 4" X 5"	1	TCS 300721	TCS 300721
Epson Printer	1	TEL TMU295-011	TEL TMU295-011
24 VDC Epson Printer Power	1	TCS 300772	TCS 300772
Wehof Order Form	1	TCS WEHOF	TCS WEHOF

## TCS 3000 Epson Slip Print 110V QD Kit (Metric TCS 300892 / NPT TCS 300992)



Item	Qty	Metric TCS P/N	NPT TCS P/N
Cable Gland M20X1.5 UL	1	TCS 300244	-
O-Ring, Buna M20 Glad	1	TCS 300245	-
Cable Gland, 1/2 NPT Gland	1	-	TCS 300254
O-Ring, 1/2 NPT Gland	1	-	TCS 300255
3 Wire Printer Comm Cable	1	TCS 300714	TCS 300714
Velcro 4" X 5"	1	TCS 300721	TCS 300721
Epson Printer	1	TEL TMU295-011	TEL TMU295-011
110VAC Epson Printer Power	1	TCS 300773	TCS 300773
Wehof Order Form	1	TCS WEHOF	TCS WEHOF

## TCS 3000 Epson Roll 12V QD Kit (Metric TCS 300890 / NPT TCS 300990)



Item	Qty	Metric TCS P/N	NPT TCS P/N
Cable Gland M20X1.5 UL	1	TCS 300244	-
O-Ring, Buna M20 Glad	1	TCS 300245	-
Cable Gland, 1/2 NPT Gland	1	-	TCS 300254
O-Ring, 1/2 NPT Gland	1	-	TCS 300255
12 VDC Epson Printer Power	1	TCS 300712	TCS 300712
3 Wire Printer Comm Cable	1	TCS 300714	TCS 300714
Velcro 4" X 5"	1	TCS 300721	TCS 300721
Roll Printer	1	TEL TMU220A103	TEL TMU220A103
Wehof Order Form	1	TCS WEHOF	TCS WEHOF

## TCS 3000 Epson Roll 24V QD Print Kit (Metric TCS 300894 / NPT TCS 300994)

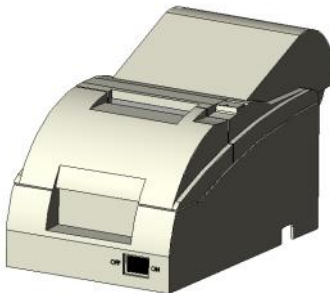

Item	Qty	Metric TCS P/N	NPT TCS P/N
Cable Gland M20X1.5 UL	1	TCS 300244	-
O-Ring, Buna M20 Glad	1	TCS 300245	-
Cable Gland, 1/2 NPT Gland	1	-	TCS 300254
O-Ring, 1/2 NPT Gland	1	-	TCS 300255
3 Wire Printer Comm Cable	1	TCS 300714	TCS 300714
Velcro 4" X 5"	1	TCS 300721	TCS 300721
24 VDC Epson Printer Power	1	TCS 300772	TCS 300772
Roll Printer	1	TEL TMU220A103	TEL TMU220A103
Wehof Order Form	1	TCS WEHOF	TCS WEHOF

**TCS 3000 Epson Roll 110V QD Print Kit (Metric TCS 300896 / NPT 300996)**

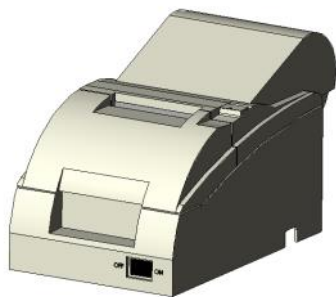

Item	Qty	Metric TCS P/N	NPT TCS P/N
Velcro 4" X 5"	1	TCS 300721	TCS 300721
Comm. Cable 35' Quick DI	1	TCS 300762	TCS 300762
Quick Disc Splitter W/2	1	TCS 300764	TCS 300764
NPT Bulkhead Comm. Fitting	1	TCS 300963	TCS 300963
AC Power Supply W/Cord	1	TEL TPS-180	TEL TPS-180
Roll Printer	1	TEL TMU220A103	TEL TMU220A103
Wehof Order Form	1	TCS WEHOF	TCS WEHOF

**TCS 3000 Blaster Printer QD Print Kit (Metric TCS300893 / TCS300993)**



Item	Qty	Metric TCS P/N	NPT TCS P/N
Velcro 4" X "5"	1	TCS 300721	TCS 300721
Comm. Cable 35' Quick DI	1	TCS 300762	TCS 300762
Bulkhead Conn. For Comm.	1	TCS 300763	TCS 300763
QD Splitter Cable	1	TCS 300774	TCS 300774
Blaster Printer	1	TCS 300775	TCS 300775
Wehof Order Form	1	TCS WEHOF	TCS WEHOF



## Installation Procedure—Remote Display

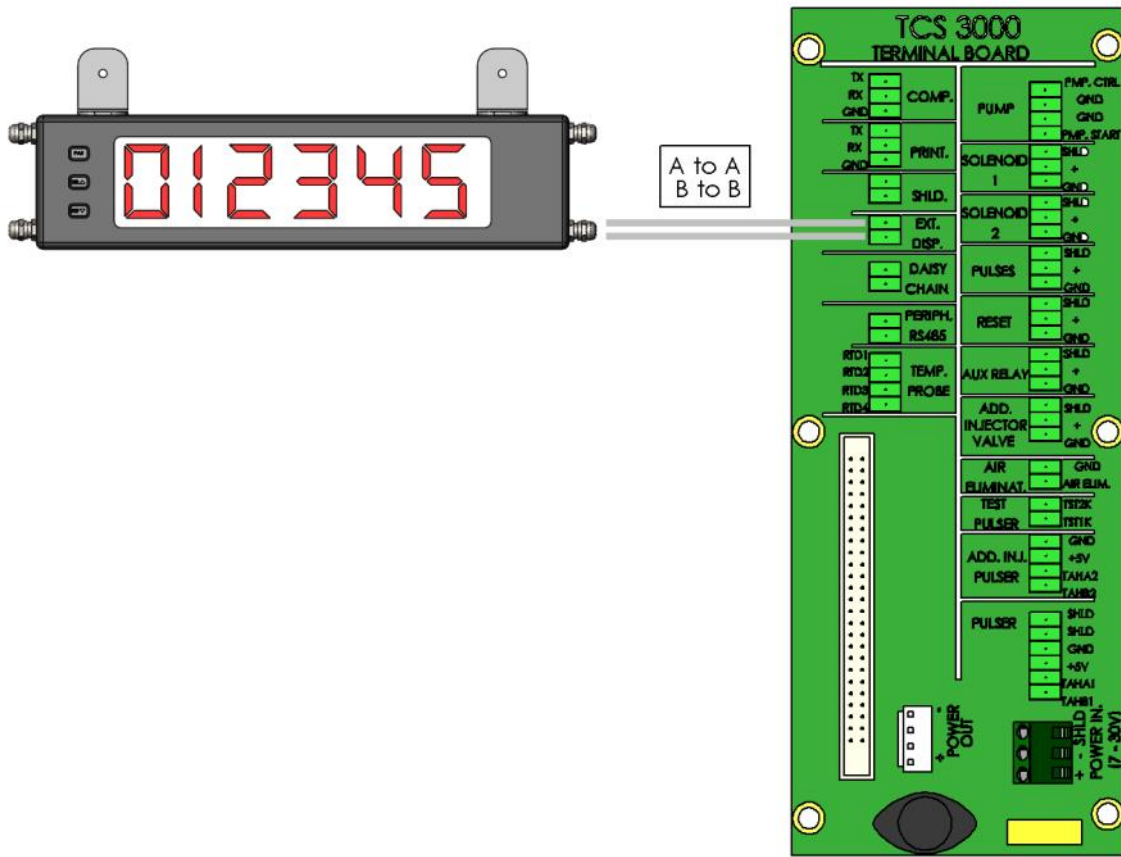

### Installation Procedure:

Instructions to follow.

# Installation Procedure—Daisy Chain Printer



## Daisy Chain:

Daisy Chain is used for linking multiple registers together to use one printer or to link multiple registers to the data-base.



To Daisy Chain the Registers use a two wire 22 gauge shielded cable. Nominate one Register to be the Host.

Once you've chosen which Register will be the Host the other Registers will be considered the clients. Strip a small amount of wire and run the wire from slot A and B of DAISY CHAIN on the Host Unit to slot A and B of DAISY CHAIN on the Client Unit.

To tie the Client to the next Client unit on the Daisy Chain, strip a small amount of wire and run the wire from slot A and B of DAISY CHAIN to slot A and B of the next client's DAISY CHAIN.



Host

Client 2

Client 3

Client 4

The Host will have 2 wires.

Client 2 will have 4 wires.

Client 3 will have 4 wires.

The Last Client will have 2 wires.



Continue to Daisy Chain until you have tied the chain together, alternating slots on the Daisy Chain until you've reached the end of the chain. The Host and the last Slave on the chain will be the only two registers on the chain to have a one wire connection.

## Daisy Chain for the Printer

Connect the Printer to the Host Register. To set the Host :

Enable the Printer:

SYSTEM MENU → SYSTEM SETTINGS → PRINTER SETTINGS → ENABLE/DISABLE PRINTER → ENABLE PRINTER

Select the Printer:

PRINTER SETTINGS → SELECT PRINTER → [SELECTED PRINTER] → ENABLE

## Selecting the Host Register

Select Register as Host:

PRINTER SETTINGS → DISABLE/ENABLE HOST → ENABLE

Select the Client Range:

PRINTER SETTINGS → PRINTER HOST → CLIENTS ADDRESS RANGE → CLIENTS RANGE START ADDRESS [ Enter 2 and Select] →

CLIENTS RANGE END ADDRESS [ Enter the number of Registers on the Chain and Select]

**\*Please Note the Host is always # 1. The Client always starts at #2\***

## Selecting the Client Register

SYSTEM SETTINGS → CONNECTIVITY SETTINGS → NETWORK SETTINGS → ADDRESS → DEVICE ADDRESS [Select the number of the unit you are using ex. 2 if it is the second register on the chain or 3 if it's the third register on the chain.]

To Connect to the Chain:

SYSTEM SETTINGS → CONNECTIVITY SETTINGS → NETWORK SETTINGS → INTERFACE BRIDGE [Only used when there are 2 Registers tied in the chain] → TRANSFER DATA BETWEEN RS232 <-> RS485 INTERFACES ENABLED

Continue the Selecting Client Register steps for every Client on the Chain.

**You may only use the Daisy Chain on five devices at a time. You may not Chain more than five devices together.**

# Installation Procedure—Daisy Chain Modem



## Daisy Chain:

Daisy Chain is used for linking multiple registers together to use one printer or to link multiple registers to the data-base.



To Daisy Chain the Registers use a two wire 22 gauge shielded cable. Nominate one Register to be the Host.

Once you've chosen which Register will be the Host the other Registers will be considered the clients. Strip a small amount of wire and run the wire from slot A and B of DAISY CHAIN on the Host Unit to slot A and B of DAISY CHAIN on the Client Unit.

To tie the Client to the next Client unit on the Daisy Chain, strip a small amount of wire and run the wire from slot A and B of DAISY CHAIN to slot A and B of the next client's DAISY CHAIN.



Host

Client 2

Client 3

Client 4

The Host will have 2 wires.

Client 2 will have 4 wires.

Client 3 will have 4 wires.

The Last Client will have 2 wires.



Continue to Daisy Chain until you have tied the chain together, alternating slots on the Daisy Chain until you've reached the end of the chain. The Host and the last Client on the chain will be the only two registers on the chain to have a one wire connection.

## Selecting the Host Register

Select Register as Host:

PRINTER SETTINGS → DISABLE/ENABLE HOST → ENABLE

Select the Client Range:

PRINTER SETTINGS → PRINTER HOST → CLIENTS ADDRESS RANGE → CLIENTS RANGE START ADDRESS [ Enter 2 and Select] →

CLIENTS RANGE END ADDRESS [ Enter the number of Registers on the Chain and Select]

**\*Please Note the Host is always # 1. The Client always starts at #2\***

## Selecting the Client Register

Enable the Printer:\*

PRINTER SETTINGS → ENABLE/DISABLE PRINTER → ENABLE PRINTER

Select the Printer:\*

PRINTER SETTINGS → SELECT PRINTER → [REMOTE] → ENABLE

SYSTEM SETTINGS → CONNECTIVITY SETTINGS → NETWORK SETTINGS → ADDRESS → DEVICE ADDRESS [Select the number of the unit you are using ex. 2 if it is the second register on the chain or 3 if it's the third register on the chain.]

To Connect to the Chain:

SYSTEM SETTINGS → CONNECTIVITY SETTINGS → NETWORK SETTINGS → INTERFACE BRIDGE [Only used when there are 2 Registers tied in the chain] → TRANSFER DATA BETWEEN RS232 <-> RS485 INTERFACES ENABLED

Continue the Selecting Client Register steps for every Client on the Chain.

**You may only use the Daisy Chain on five devices at a time. You may not Chain more than five devices together.**

# Installation Procedure—Wiring Diagrams



## Standard Wiring

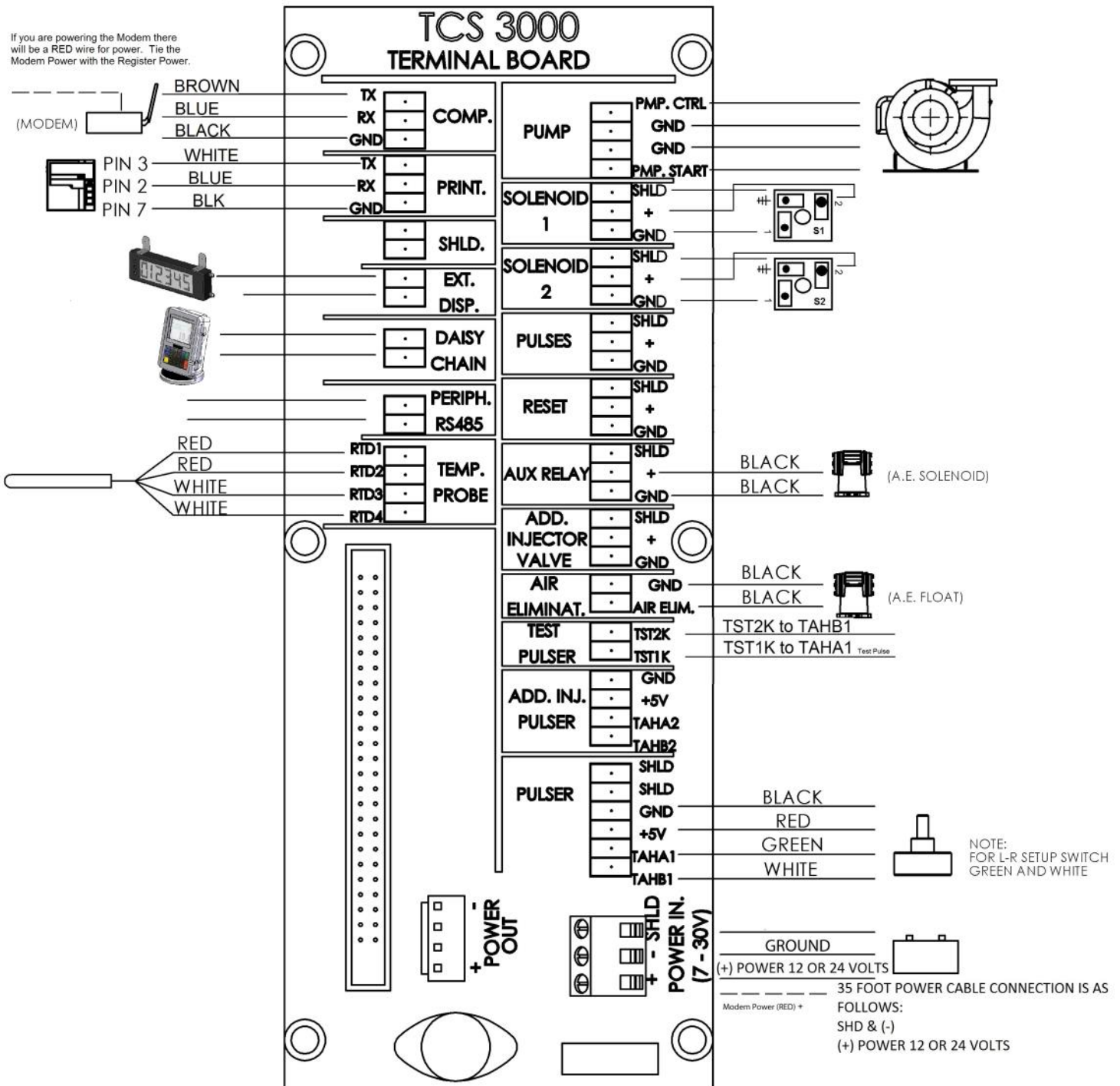

## Quick Disconnect Wiring

If you are powering the Modem there will be a RED wire for power. Tie the Modem Power with the Register Power.

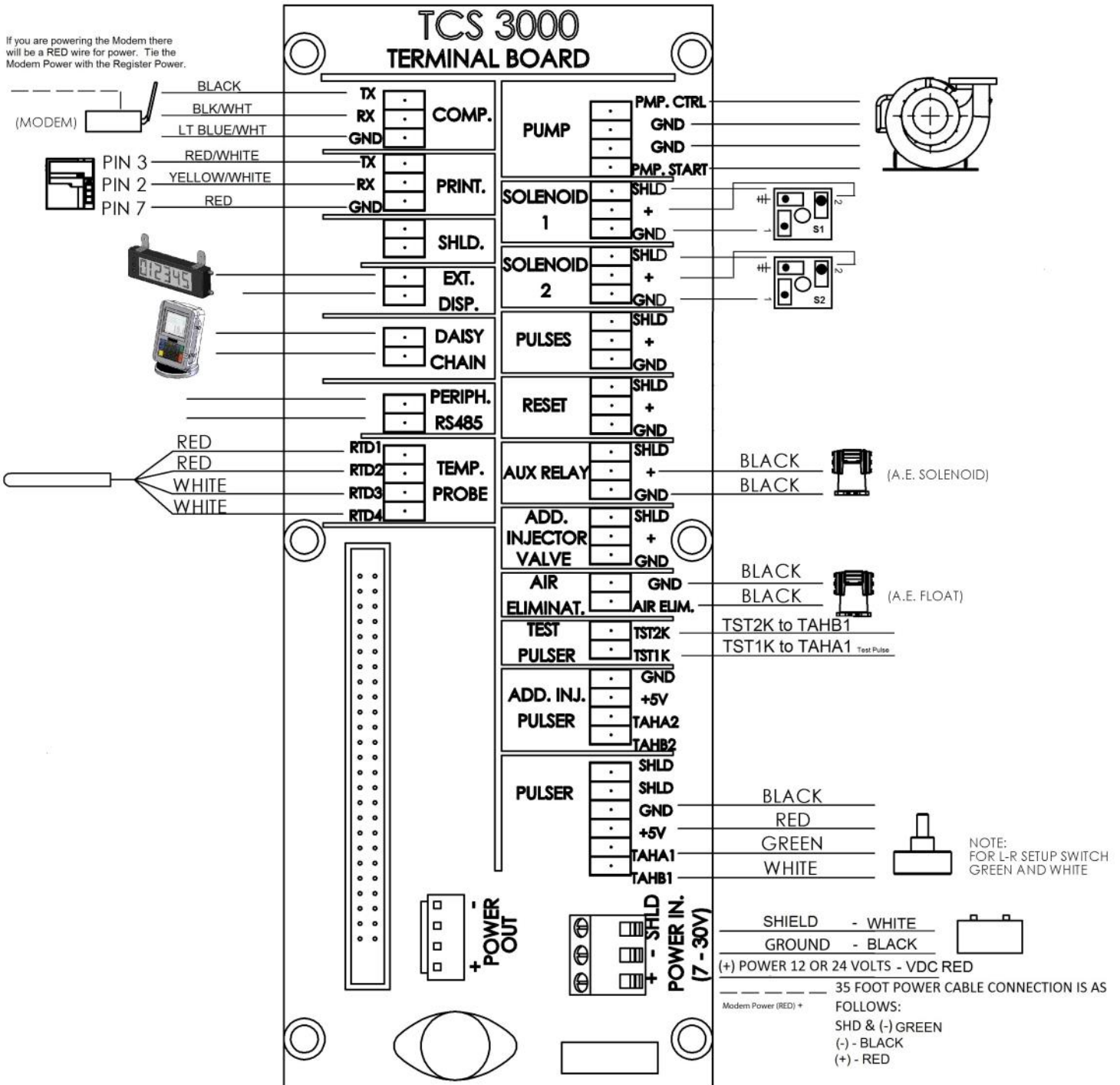

## Installation Procedure—Software Update

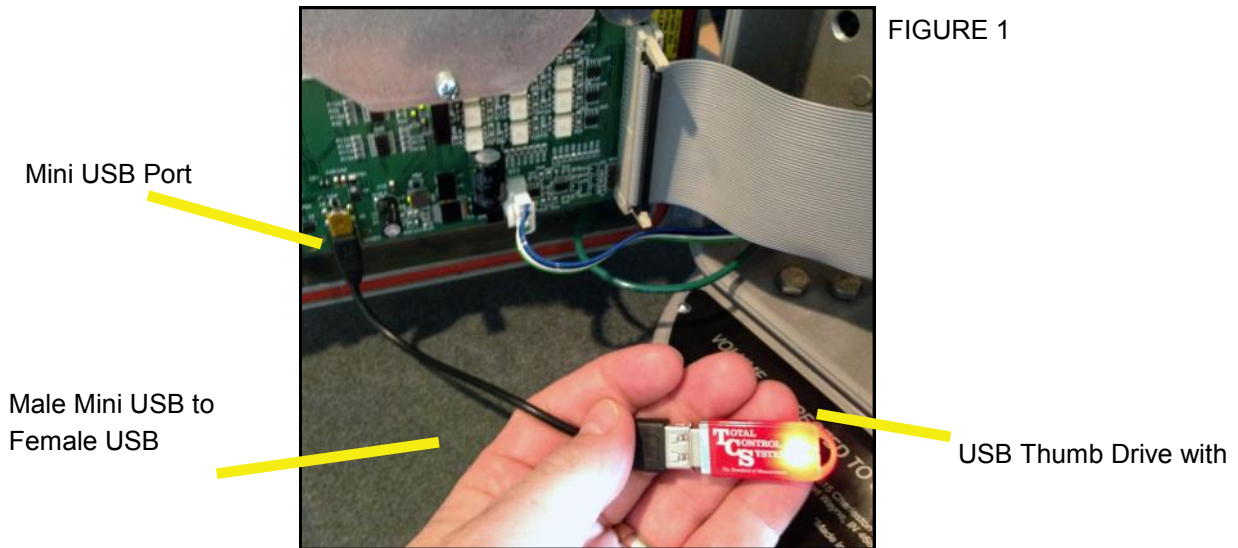

Item	Qty	TCS P/N
USB FEM/Mini Male Cable	1	TCS 300705
TCS 3000 USB	1	TCS 300795

TCS 3000 Software Update Kit (TCS 300882)

### Installation Procedure:

Procedure to upload new software is as follows:

1. Load new software upgrade to a USB thumb drive (dongle).

**NOTE:** The new software upgrade should be the ONLY file on the drive.

2. Open the TCS 3000 register. On the front cover of the register, there are 2 mini-USB connections. Using a factory supplied USB cable, attach the thumb drive to the USB port closest to the inside of the register. This port is the highest on the circuit board of the two. See Figure 1.
3. Plug the USB cable into the USB port, and then insert the USB thumb drive into the mating cable (see Figure 1).
4. Under Advanced Functions, locate System Update and press ENTER.
5. The screen will display System Update, press MODE to continue with the update.
6. If the thumb drive is not recognized or there is a faulty cable, the display will respond with NO UPDATE DATA error message.
7. Once the file is recognized, you will be prompted to remove the media. Remove the USB and the register will re boot and begin the update process. This should take approximately 4 minutes.



## Installation Procedure—Warranty Information



### WARRANTY

New 3000 electronic registers, equipment or components manufactured by Total Control Systems, a division of Murray Equipment, Inc. (TCS) with which this warranty is enclosed, are warranted by TCS to the original purchaser only for a period of TWELVE (12) months from installation or eighteen (18) months from the date of shipment, to be free, under normal use and service, from defects in material and workmanship.

Defects occurring within the stated warranty period, TCS will repair or replace, at TCS's option; provided that part or parts are returned to TCS transportation charges prepaid, and TCS's examination discloses the parts or workmanship to have been defective upon delivery to the purchaser.

### EXCLUSIONS

Warranty does not cover any parts and equipment not manufactured by TCS, but these items may be covered by separate warranties of their respective manufacturers. This warranty does not extend to any equipment that has been subjected to misuse, negligence or accident or if operated in any manner other than in accordance with TCS's operating instructions and specifications.

### CLAIM PROCEDURES

In order to obtain performance by TCS of its obligations under this warranty, the original purchaser must obtain a Return Goods Authorization (RGA) number from TCS's customer service department within 30 days of discovery of a purported breach of warranty, but not later than the expiration of the warranty period. Once authorization is received, return the defective meter, piece of equipment, or component covered by this warranty, with transportation charges prepaid, to TCS at the address shown below together with a written statement setting forth the nature of the defect and RGA number.

### LIMITATIONS

THERE ARE NO OTHER WARRANTIES OF ANY KIND, EXPRESS OR IMPLIED. TCS SPECIFICALLY DISCLAIMS ANY WARRANTY OF MERCHANTABILITY OR OF FITNESS FOR ANY PARTICULAR PURPOSE. TCS will determine if all parts or meter defect falls within the warranty guidelines and will repair or replace within a reasonable time span. TCS is not responsible for any in or out bound freight. TCS's sole obligation that shall represent the buyer's sole and exclusive remedy shall be to repair or at TCS's option to replace any product or part determined to be defective. In no event shall TCS be liable for any special, direct, indirect, incident, consequential or other damages of similar nature, including without limitation, loss of profits, products, production time, or loss of expenses of any nature incurred by the buyer or any third party. TCS has not authorized on its behalf any representation or warranties to be made, nor any liability to be assumed except as expressly provided herein; there is no other express or implied warranty.

### DESIGN AND EQUIPMENT CHANGES

Any changes in design or improvements added shall not create any obligation to install same on equipment previously sold or ordered.





**TOTAL  
CONTROL  
TCS SYSTEMS**

*"The Standard of Measurement"*

2515 Charleston Place  
Fort Wayne, IN 46808

Toll Free: (800) 348-4753  
Phone: (260) 484-0382  
Fax: (260) 484-9230  
Email: [sales@tcsimeters.com](mailto:sales@tcsimeters.com)  
Website: [www.tcsimeters.com](http://www.tcsimeters.com)