

# TOTAL CONTROL SYSTEMS TCS

Toll: +1 (800) 348-4753  
Tele: +1 (260) 484-0382  
Fax: +1 (260) 484-9230  
info@tcsimeters.com  
www.tcsimeters.com

## ENGINEERING MANUAL 700 SERIES ROTARY FLOW METER

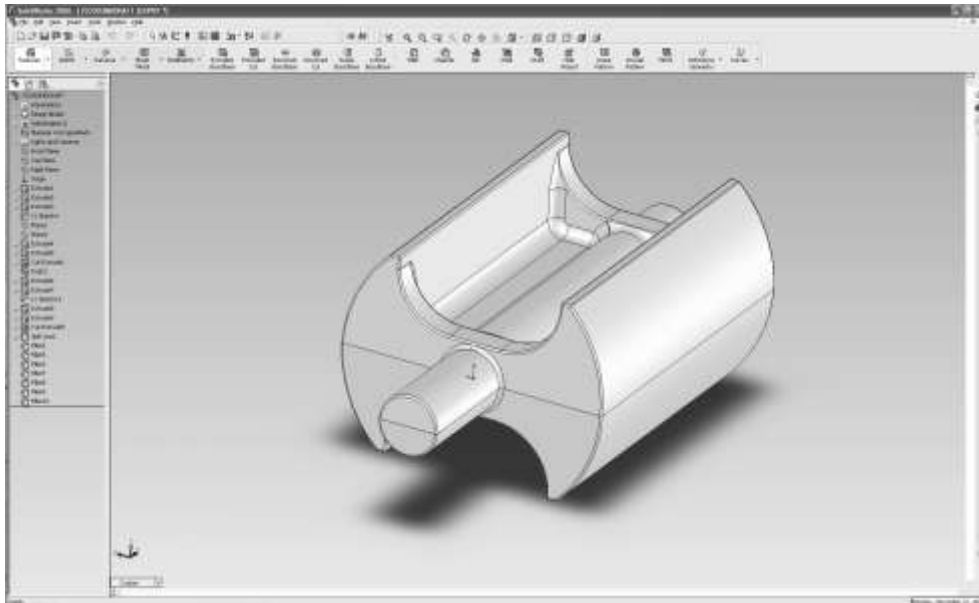

## TABLE OF CONTENTS

	Page No.
Table of Contents	1
Quote and Purchase Specifications	2
Rotary Design	3
Meter Type Classification	4
Meter Selection Factors	
Metrology	5
Accuracy	6
Material Compatibility	6
Flow Rate	6
Pressure	6
Temperature	7
Lubricity	7
Suspension and Suspended Solids	7
Foreign Materials	8
PH	8
Viscosity	8
Pressure Loss	9
Bearing Load	10
System Design	
Plumbing Figuration	10
Slow Flooding of System	11
Protection From Debris	11
Calibration	11
Drum Filling System	12
Mobile Fueling System	13
Hydraulic Shock	14
Thermal Expansion	14
Thermal Shock	14
Products that Dry/Congel/Crystallize	14
LPG	14
Meter Calibration	16 - 18
Product Depletion (Split Compartment)	18 - 20
Calibration Procedure	21
Direction of Flow	22
700 Series Materials of Construction	23
Chemical Compatibility	23 - 35
Metric Conversion Guide	36
Registration Specifications	
Gear Plate Information	37
Pulse Output	38
Approximate Weights	39
Glossary	40 - 42
Material Safety Data Sheet (MSDS) for Calibration Fluid	43 - 46

## QUOTE & PURCHASE SPECIFICATIONS

When issuing quote and purchase specifications and to assure you of receiving a Total Control Systems meter with all of the many performance, installation, operating, and maintenance advantages available only with a TCS meter. We suggest that 700 series meter-engineering specifications include the following statements in addition to a TCS model number and description.

“Meter shall be of a flow meter with a positive displacement design having rotary motion without axial thrust or flow disruption. No eccentric, sliding, reciprocating or oscillating parts to induce excess liquid shear or liquid compressibility within meter element. Meter shall have three rotors that rotate in unison within the measuring chamber. Rotary parts to be horizontally supported on both sides by solid support bearings and rotor journals of materials compatible with product to be metered. Meter shall have stainless steel timing gears with no ball bearings, springs, or cams. Rotary drive and meter adjustment output to all mechanical readout shall be capable of infinite meter accuracy adjustment of 0.02% or better. Meter calibration adjustment device must be externally accessible not requiring removal of any readout equipment for calibration or replacement. Meter shall immediately respond to product low flow movement.”

## NOTICE

Total Control Systems (TCS) shall not be liable for technical or editorial errors in this manual or omissions from this manual. TCS makes no warranties, express or implied, including the implied warranties of merchantability and fitness for a particular purpose with respect to this manual and, in no event, shall TCS be liable for special or consequential damages including, but not limited to, loss of production, loss of profits, etc.

The contents of this publication are presented for informational purposes only, and while every effort has been made to ensure their accuracy, they are not to be construed as warranties or guarantees, expressed or implied, regarding the products or services described herein or their use or applicability. We reserve the right to modify or improve the designs or specifications of such products at any time.

TCS does not assume responsibility for the selection, use or maintenance of any product. Responsibility for proper selection, use and maintenance of any TCS product remains solely with the purchaser and end-user.

***All rights reserved. No part of this work may be reproduced or copied in any form or by any means – graphic, electronic or mechanical – without first receiving the written permission of Total Control Systems, Fort Wayne, Indiana USA.***

## DESIGN

The TCS Model 700 series flow meter is a simple and efficient design. The meter consists of a single fluid chamber that contains a single blocking rotor and two displacement rotors whose rotation is synchronized with mating gears. As the fluid enters the fluid chamber, the blocking rotor is forced to rotate. The displacement rotors, also rotating in conjunction with the blocking rotor help direct the fluid flow through the chamber and to the outlet. The linear flow of the fluid is thus translated into rotary motion in the meter. The output of the meter is picked up from the rotation of the blocking rotor and transmitted to a register or pulse transmitter.

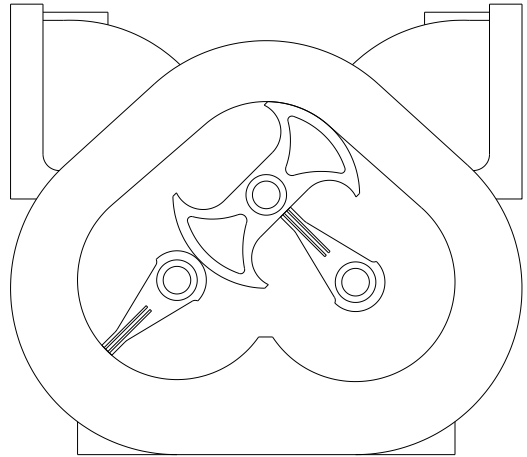

The rotors in the meter are designed to operate at close tolerances to one another and the wall of the fluid chamber. There are slight gaps between the rotors and the chamber wall. Because of this, it is important that the meter be properly applied for the flow rate and operating pressure of the system.

Because the fluid flowing through the meter is redirected only slightly from its natural flow, there is very little pressure drop across the meter, unlike other meters that use multiple measuring chambers.

The meter design uses high quality long life materials for the rotor bearings and journals. Since there is no contact between the rotors and the fluid chamber wall, these critical components have a long life expectancy.

Calibration of the meter involves adjusting the rotation of the output shaft relative to the rotation of the internal rotors of the meter. This is accomplished by changing the settings on an adjuster device. Calibration of the meter is discussed in detail in the section Meter Calibration.



700 METER FLOW ILLUSTRATION

## METER TYPES

### **SP STANDARD PETROLEUM**

For metering refined petroleum products such as Leaded and Unleaded Gasoline, Fuel Oils, Diesel, Bio-Diesel, Kerosene, Vegetable Oils, Motor Oils, Ethylene Glycol (Antifreeze), etc.

### **SPA STANDARD PETROLEUM (AVIATION)**

For metering refined petroleum products such as Aviation Gasoline, Jet Fuels, Gasoline, Fuel Oils, Diesel, Bio-Diesel, Kerosene, Motor Oils, etc.

### **SPD STANDARD PETROLEUM (DUCTILE IRON)**

For metering alternative fuels such as Natural Gasoline, Ethanol, Methanol, Bio-Diesel, Aviation Gasoline, Fuel Oils, Diesel, Motor Oils, etc.

### **LP LIQUEFIED PETROLEUM**

For metering Liquefied Petroleum Gas (LPG).

### **IP INDUSTRIAL PRODUCTS**

For metering Food Products, Industrial Products, General Solvents and many other liquids; such as Liquid Sugars, Corn Syrup, Soy Bean Oil, Shortenings, Latex Products, Adhesives, etc.

### **IC INDUSTRIAL PRODUCTS WITH CARBON BEARINGS**

For metering Industrial Chemicals, General Solvents, Water and other Non-lubricating Liquids, such as Alcohol, Acetones, Ethanol, Naphtha, Xylene, MEK, Toluene, Deionized Water, Demineralized Water, Potable Water, etc.

### **AF ALL FERROUS**

For metering Pesticides, Nitrogen Solutions, Fertilizer, Chlorinated Solvents, Paints, Inks, Alcohols, Adhesives, Motor Oils, Molasses, Corn Syrup, Liquid Sugars, etc.

### **SS STAINLESS STEEL**

For metering the same liquids as the SP, SPA, SPD, IP, IC and AF flow meters, but includes food processing and special handling fluids such as Nitric, Phosphorus and Glacial Acetic Acids, Anti-Icing Fluids, Vinegar, Fruit Juices, etc.

## METER OPERATING SPECIFICATIONS

Meter	Type Available	Flange Connection*	Maximum Capacity	Working Pressure	Working Temperature**
700-15	SP, SPA, IP & IC	1½" NPT Flange; 2" optional	60 GPM (227 LPM)	150 PSI (10.5 BAR)	-40°F to 160°F (-40°C to 71°C)
700-20	SP, SPA, SPD, IP, IC, AF & SS	2" NPT Flange; 1½" optional	100 GPM (380 LPM)	150 PSI (10.5 BAR)	-40°F to 160°F (-40°C to 71°C)
700-20	LP	2" NPT Flange; 1½" optional	100 GPM (380 LPM)	350 PSI (24.1 BAR)	-30°F to 140°F (-30°C to 60°C)
700-25	SPA, SPD	2" NPT Flange	150 GPM (567 LPM)	150 PSI (10.5 BAR)	-40°F to 160°F (-40°C to 71°C)
700-30	SP, SPA, SPD, IP, IC & AF	3" NPT Flange 2" optional	200 GPM (760 LPM)	150 PSI (10.5 BAR)	-40°F to 160°F (-40°C to 71°C)
700-35	SPA, SPD	3" NPT Flange	300 GPM (1135 LPM)	150 PSI (10.5 BAR)	-40°F to 160°F (-40°C to 71°C)
700-40	SP, SPA, SPD, IP, IC & AF	4" NPT Flange; 3" optional	500 GPM (1893 LPM)	150 PSI (10.5 BAR)	-40°F to 160°F (-40°C to 71°C)
700-45	SPA, SPD	4" NPT Flange	600 GPM (2271 LPM)	150 PSI (10.5 BAR)	-40°F to 160°F (-40°C to 71°C)

\* Flanged NPT is Standard; BSPT, Slip Weld, ANSI and others are available upon request.

\*\* Higher working temperatures can be achieved at reduced pressures (consult factory for more information)

## METER SELECTION FACTORS

### WEIGHTS&MEASURES

Before any meter can be specified, knowledge of each application is required. If the liquid is to be sold through a metered delivery, domestic or international certification from a governing body may be required. Total Control Systems strictly adheres to all domestic and international metrology conformance regulations for the custody transfer of fluids. For questions regarding weights and measures approvals or other issues, please consult factory.

## TYPICAL ACCURACY CURVE

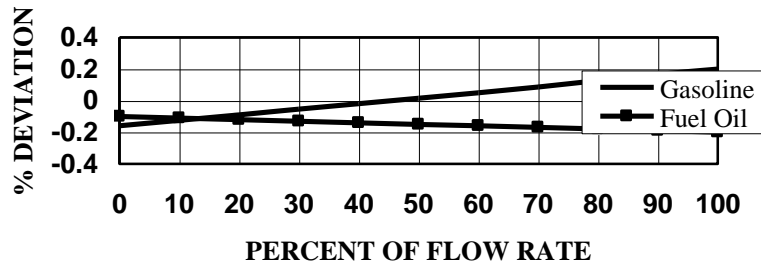

The 700-meter's accuracy (percent of error over or under the zero – error level) remains within design parameters ( $\pm 0.15\%$ ) over its minimum rated flow range to its maximum rated flow range for custody transfer meter requirements. This percentage meets or exceeds the Wholesale and Vehicle accuracy requirements for accurate custody transfer of product, as specified in the National Institute of Standards and Technology (NIST) Handbook 44.

## PRODUCT CHARACTERISTICS

### A) Material Compatibility

The product intended to be measured must review Total Control Systems CHEMICAL COMPATIBILITY on page 23 to 35 to find the suitable materials and meter type. Materials incompatible with product will potentially reduce accuracy, operation life, contaminate liquid and may be harmful to others.

### B). Flow Rate

The minimum and maximum system rate of flow must be determined for the selection of flow meter. The flow rate of the system is dependent upon the product viscosity; the desired meter configuration, the systems pump capabilities, and the plumbing configuration.

### C) Pressure

The maximum working pressure allowed should be reviewed under flow meter type and pressure rating. All meters meet the European Pressure Equipment Directive (PED) No. 97/23/EC. Failure to adhere to the maximum allowable pressure may potentially cause a seal leak or casting rupture.

D) Temperature

The operating temperature has a great effect on the meter seals and its relationship to the maximum pressure allowed with the flow meter castings. It will be necessary to reduce the maximum rated working pressure as the operating temperature increases. Any metering system operating over 160F (71C) will require extra clearance rotors to compensate for material expansion. Any metering system operating over 180F (82 C) will require at least a one (1) foot registration extension to protect the registration devices. Increase in temperature may increase the corrosion rate of some products.

- 1) O-ring / Packing Seal Temperature Rating
 

UL Buna	-20F to 140F	-30C to 60C
UL Viton	-104F to 221F	-75C to 105C
Viton	-31F to 400F	-35C to 204C
Simriz	-40F to 450F	-10C to 230C
Teflon	-20F to 500F	-30C to 260C

*The Acetyl Face Gear and Bushings, in the register support assembly;  
maximum temperature is 180F (82C)*

- 2) Pressure rating at elevated temperatures.

Meter Type	
SP/SPA/SPD/IP/IC/AF/SS	LP
150F/150PSI	150F/350PSI
200F/100PSI	200F/275PSI
250F/75PSI	250F/250PSI
300F/50PSI	300F/150PSI

E) Lubricity

The lubricity or non-lubricity of the product will determine the bearing sleeve material suitable for use. Products with no lubrication will require the use of Carbon Graphite or Ceramic bearing sleeves. Products with lubrication will reduce friction between two metal surfaces and help dissipate heat.

F) Suspensions & Suspended Solids

Products with a low percentage of soft suspensions or suspended solids will require clearance rotors and/or Ceramic bearing sleeves to protect the meter from its abrasive effects. High percentages (5%) of suspensions or suspended solids, or any hard solids, such as sand, are not recommended for the 700 series meter. Due to the very tight machining tolerances any solid, larger than the thickness of a piece of paper, has the potential of stopping the flow through the meter and can cause damage to the meter.



### G) Foreign Materials

Products that are to be measured may have foreign materials present. The inlet side of any positive displacement meter should be equipped with a strainer. Matching the strainer size or one size larger, with an appropriate size screen will protect the meter and accessories from damage in the system. A minimum of 40-mesh screen is recommended for petroleum service.

### H) pH

The metal resistance to the effects of high or low PH is difficult to calculate because of the varying concentrations and corrosiveness of properties. This is a generalized rating for pH resistance.

Material	pH
Aluminum	5 – 8
Ductile Iron	5.5 – 11
Ni-Resist	5.5 – 14
Stainless Steel	0 – 14

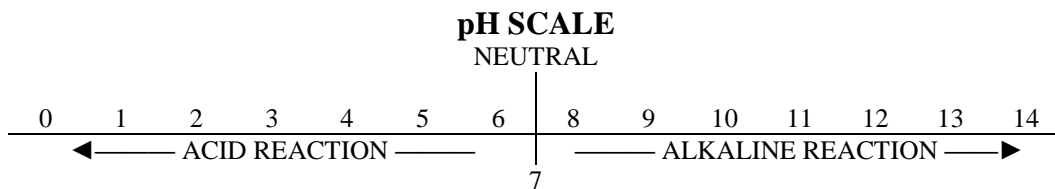

### I) Viscosity

Viscosity is the property of a fluid that is a measure of its resistance to flow. Among the earliest to express this quantitatively was Sir Isaac Newton. He reasoned that the viscosity of a liquid was proportional to its shear stress (or resistance to shear). Liquids that behave in this manner are referred to as “Newtonian” liquids and are typically by petroleum fluids, water and similar chemicals.

Other types of fluids are grouped into a general category called “Non-Newtonian” which includes dilatants, plastic, pseudoplastic and thixotropic. Liquids in this group are characterized by viscosity that changes with the rate of shear as compared to the Non-Newtonian fluids where viscosity is basically constant with shear and flow rate. As a consequence, Newtonian fluids are much easier to predict with regard to their performance through a flow meter than are the Non-Newtonian liquids.

Many of the more viscous liquids pumped through the 700 series rotary flow meter are plastic and pseudoplastic and as such are reduced in effective viscosity after being pre-sheared by the pump. The diagram below shows how viscosity varies as a function of shear rate on various types of liquids.

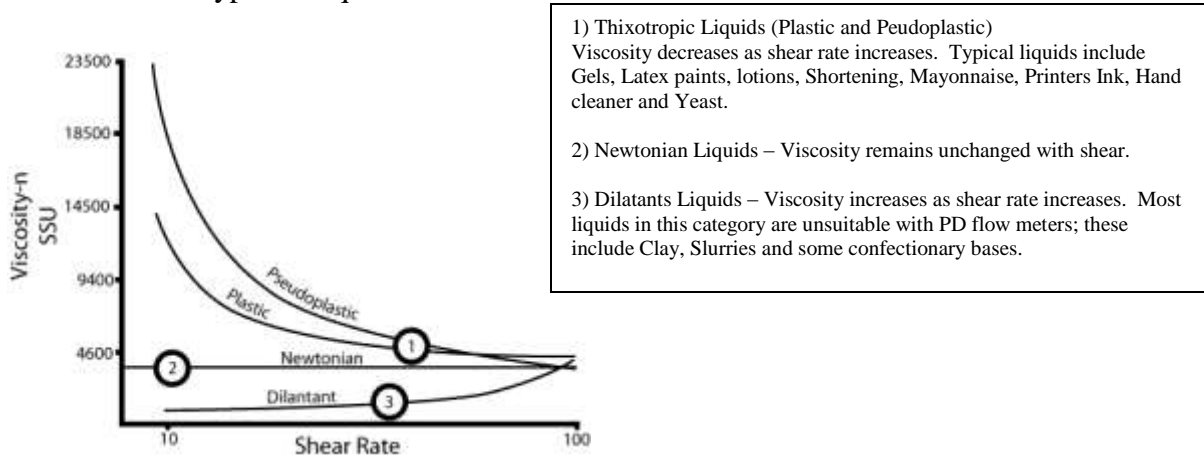

J) Pressure Loss

The pressure drop is the difference between of the inlet and outlet pressure of the flow meter while operating. When measuring a liquid, the pressure drop will increase as the flow rate increases. When the metering system has accessories such as an air eliminator or valve, these items will be approximately the same pressure drop through equivalent size meter.

**PRESSURE DROP CURVE  
32 SSU SOLVENT**

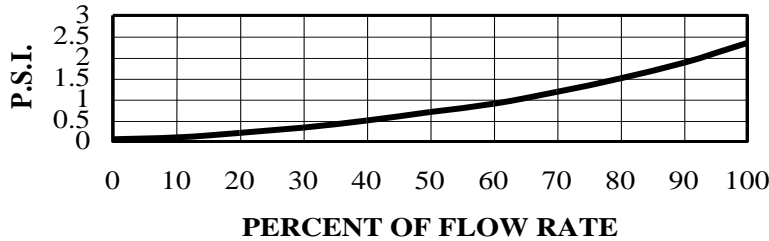

CONVERSION FACTOR		
SSU	=	Multiplier
30	=	1.0
100	=	1.5
500	=	2.5
1000	=	3.2
2000	=	4.0
3000	=	4.7
4000	=	5.0
5000	=	5.5
7500	=	6.5
10000	=	7.0
25000	=	10.0
50000	=	13.5

EXAMPLE:

A 700-20SP flow meter, air eliminator, strainer and preset valve. Operating at 80 GPM on a 2000 SSU lubricating oil.

Flow Meter: 1.5 PSI x 4.0 = 6 PSI Pressure Loss  
 Air Eliminator/Strainer: 1.5 PSI x 4.0 = 6 PSI Pressure Loss  
 Preset Valve: 1.5 PSI x 4.0 = 6 PSI Pressure Loss  
 Total Pressure Loss is 18 PSI

**VISCOSITY CONVERSION  
(Specific Gravity = 1)**

CPS Centipoise	SSU Saybolt Universal	CPS Centipoise	SSU Saybolt Universal	CPS Centipoise	SSU Saybolt Universal	CPS Centipoise	SSU Saybolt Universal
1	31	200	1,000	900	4,300	7,000	32,500
2	34	220	1,100	1,000	4,600	8,000	37,000
4	38	240	1,200	1,200	5,620	8,500	39,500
7	47	260	1,280	1,300	6,100	9,000	41,080
10	60	280	1,380	1,400	6,480	9,500	43,000
15	80	300	1,475	1,500	7,000	10,000	46,500
20	100	320	1,530	1,700	8,000	15,000	69,400
25	130	340	1,630	1,800	8,500	20,000	92,500
30	160	360	1,730	1,900	9,000	30,000	138,500
40	210	380	1,850	2,000	9,400	40,000	185,000
50	260	400	1,950	2,200	10,300	50,000	231,000
60	320	420	2,050	2,400	11,200	60,000	277,500
70	370	440	2,160	2,500	11,600	70,000	323,500
80	430	460	2,270	3,000	14,500	80,000	370,000
90	480	480	2,380	3,500	16,500	90,000	415,500
100	530	500	2,480	4,000	18,500	100,000	462,000
120	580	550	2,660	5,000	23,500	125,000	578,000
140	690	600	2,900	5,500	26,000	150,000	694,000
160	790	700	3,380	6,000	28,000	175,000	810,000
180	900	800	3,880	6,500	30,000	200,000	925,000

$$\text{Centistokes} = \frac{\text{Centipoise}}{\text{Specific Gravity}}$$

$$\text{Centipoise} = \text{Centistokes} \times \text{Specific Gravity}$$

### K) Bearing Load

The product viscosity will have a direct relationship on the flow rate of the system. The following chart is a flow meter selection guide based on the relationship of viscosity and flow rate. The bearing material is illustrated according to maximum bearing load allowable. In the following flow chart, please choose the system flow rate and the product viscosity. Then select the proper bearing sleeve material to identify the flow limitations of the flow meter. If the system flow rate and viscosity do not meet your requirements, choose the next size of flow meter or reduce the flow rate.

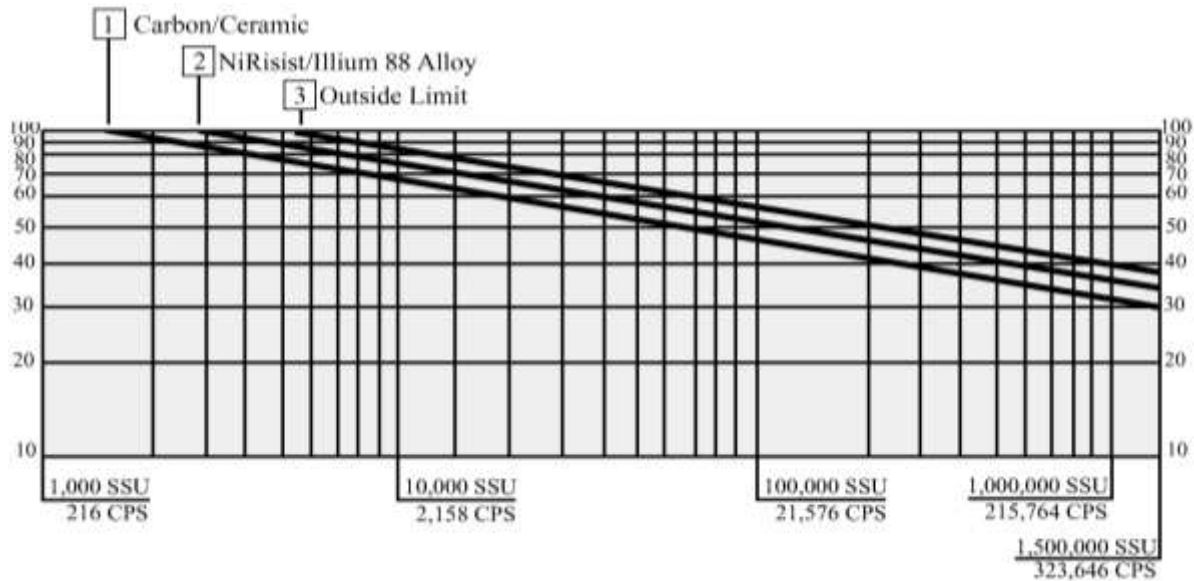

## SYSTEM DESIGN

### Meter Selection

The flow meter must be carefully chosen from the Meter Selection factors in the Engineering Manual. The meter must be selected based on the operating system and product characteristics. System variables include flow rate, temperature and pressure. The product characteristics include the material compatibility, lubricity, viscosity, suspensions, pH, and whether the product can congeal, crystallize or leave a dry film. Failure to select the correct flow meter may result in system failure or serious injury.

### Air Elimination

In any system that the tank may be completely drained or multiple products manifold into one metering system, the possibility of air being present increases. The solution is an air or vapor eliminator located before the flow meter to vent the air or vapor from the system before it can be measured. Air or vapor elimination is required for all weights and measures regulatory approvals in custody transfer applications.

### Control Valves

Safety and isolation valves should be used throughout the metering system. In any pumping system where there is one (1) pump and multiple flow meters, a digital or hydro-mechanical Rate-of-Flow control valve must be used at each flow meter to prevent over speeding of the flow meters.

### Best Plumbing Configuration

- 1). Flow meter must have secure mounting to a riser stand or the foundation.
- 2). The inlet and outlet piping must be securely supported, in a manner of not to allow pipe stress on flow meter.
- 3). System should be designed to keep the flow meter full of liquid at all times.
- 4). System piping should have the same full pipe diameter or larger as the flow meter, throughout the metering system to allow for minimal pressure loss.
- 5). The pipe should be laid out as straight as possible to reduce pressure loss from flow restriction.
- 6). The meter and piping must be installed in such a way as to avoid accidental draining of the meter. Meter inlet and outlet should be lower than the associated system plumbing (sump position).
- 7). It is not necessary for the air eliminator to be installed bolted directly to the meter. It can be installed upstream from the meter. For effective operation of the air eliminator, it should be mounted between the meter and any valves, tees or any other potential places where air may enter the system.
- 8). The metering system should include a means for calibration.

### Protection From Debris

On new installations, care must be taken to protect the meter from damage during start-up. It is recommended to put a strainer before the meter. Damage may result from the passage through the meter of dirt, sand, welding slag or spatter, thread cuttings, rust, etc. The insertion of a spool (a flanged length of pipe equal in length to the meter and accessories attached to the meter) in place of the meter until the system is flushed, temporarily bypassing the plumbing around the meter, will also protect the meter from debris. Once the system has run “clean” for a period of time the meter may be reinstalled or protective devices removed.

### Thermal Expansion

As with most liquids, they will expand and contract with temperature. In any system where there is a chance for liquid to be captured between closed valves without relief, thermal expansion will likely occur and create dangerously high pressures within the system. Care should be taken in designing the system in which thermal shock may occur by implementing Pressure Relief Valves or Thermal Expansion Joints in the system design.

When product is trapped within the system, the pressure will increase by 126 PSI (8.69 BAR) for every one (1) temperature degree increase.

### Thermal Shock

The system operating temperature will expand or contract the metals within the flow meter. For systems that have sudden or immediate temperature increases of 68 F (20 C) degrees or more, will require clearance rotors. Clearance rotors will be necessary to eliminate the effect of immediate expansion of the rotors vs. meter body, caused by thermal shock.

### Hydraulic Shock (Water Hammer)

Hydraulic shock is a rise in pressure, which happens when an operating system has immediate change in direction of flow such as a fast valve closure at a high operating flow rate. Hydraulic shock can damage any item in the way of the product flow such as internal parts of the meter, valves, and pump. System design and improper operating procedures will elevate this problem. The use of 2-stage preset control valves or surge suppressing bladders or risers will help reduce or eliminate this problem.

To compute the shock pressure when a valve is closed quickly (recommended to be less than 6 PSD):

$$\text{Shock Pressure (PSI)} = 63 \times \text{Velocity (FPS)}$$

In order to eliminate hydraulic shock, you need to slow down the valve closure rate. The time required to close the valve so that the line pressure will not exceed the normal pressure at no flow is:

$$\text{Time (seconds)} = \frac{0.027 \times L \times V}{N - F}$$

- V = Velocity in Feet/Seconds
- L = Length of pipe before the valve in feet
- N = Line pressure at no flow
- F = Line pressure at full flow

### Products that Dry/Congea/Crystallize

There are many liquids that crystallize, harden and/or solidify on contact with air or with an increase in temperature. A proper system design and a good understanding of the product being measured will help to avoid the possibility of air entering into the system and the product being affected.

### Calibration

The meter shall be tested and calibrated with the product it is intended to measure when installed. Total Control Systems shall not be responsible for loss of product or any damages resulting from the end user's failure to test this meter to insure proper calibration. Every 700 series meter is tested and calibrated at the factory to prove it is calibratable in your system. It is the owner's responsibility to report this device to the local Weights and Measures officials for their inspection before the meter is put to use. Refer to the Material Safety Data Sheet of the calibration fluid used in testing on pages 43 to 46 for more information.

PARTS LIST

ITEM	DESCRIPTION
1	PUMP
2	PUMP MOTOR
3	FLOW METER V/ REGISTER
4	STRAINER/VAPOR ELIMINATOR
5	ISOLATION VALVE
6	LIQUID LEVEL CONTROL DEVICE (OPTIONAL)
7	CHECK VALVE
8	PRESSURE GAUGE (OPTIONAL)
9	TEMPERATURE GAUGE (OPTIONAL)
10	FLOW RATE CONTROL VALVE
11	CHECK VALVE
12	FILL NOZZLE
13	SUPPLY TANK
14	PRESET VALVE (OPTIONAL)
15	SAFETY VALVE

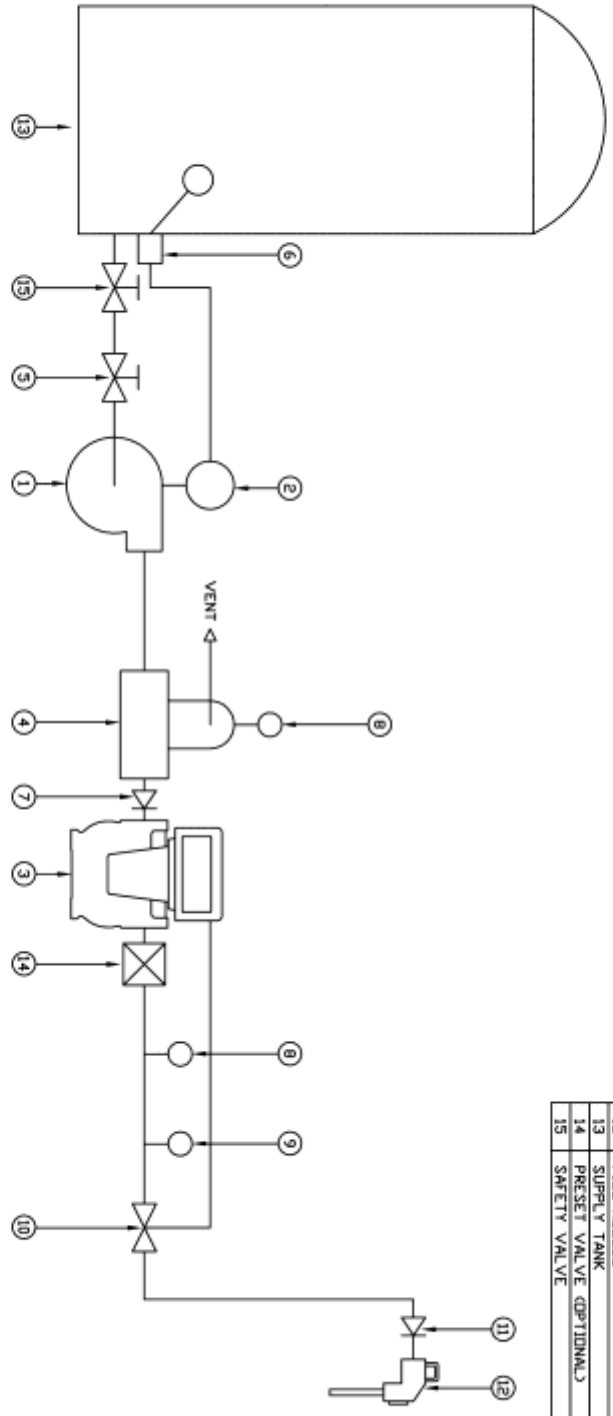

THE DRAWING AND THE INFORMATION CONTAINED HEREIN ARE CONFIDENTIAL AND PROPRIETARY TO MURRAY EQUIPMENT, INC. THE DRAWING MAY NOT BE COPIED OR DISCLOSED TO OTHERS WITHOUT EXPRESS WRITTEN PERMISSION OF MURRAY EQUIPMENT, INC.

CONFIDENTIAL  
 ZERO-TALING LIQUID-HANDLING SYSTEM

FOR  
 TOTAL CONTROL SYSTEMS  
 A DIVISION OF  
 MURRAY EQUIPMENT, INC.

DATE: 08/16/06  
 BY: [Signature]  
 REV: SEP 06

DRAWING NUMBER  
 TCS00111

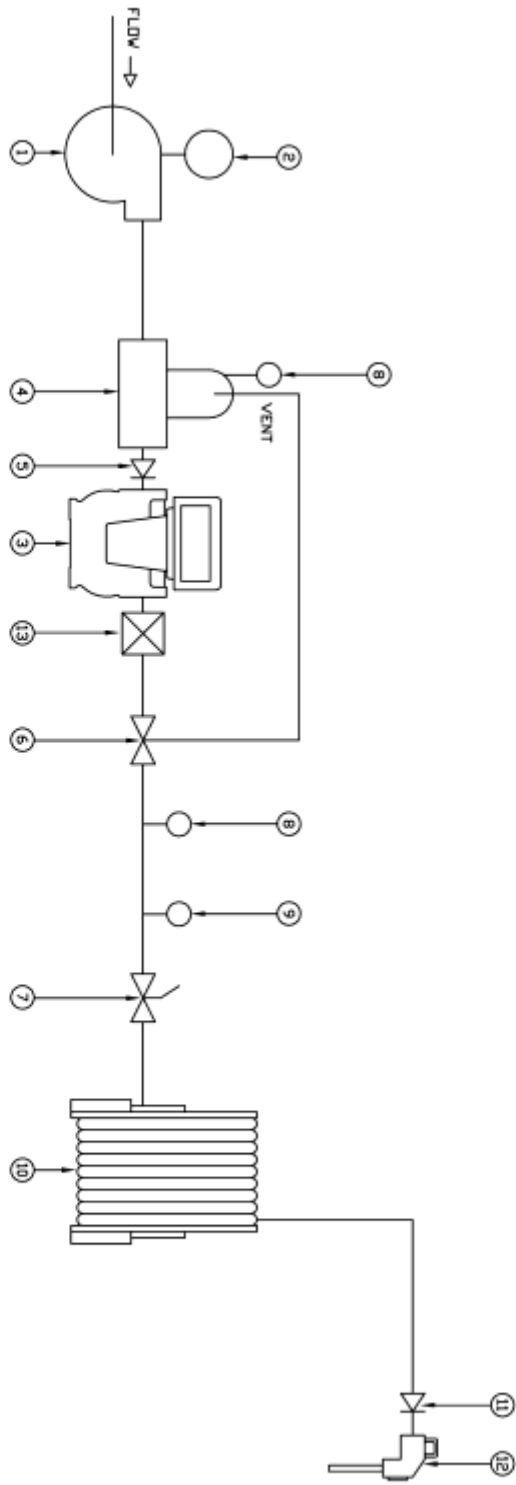

PARTS LIST	
ITEM	DESCRIPTION
1	Pump
2	PUMP MOTOR
3	FLOW METER V/ REGISTER
4	STRAINER/VAPOR ELIMINATOR
5	CHECK VALVE
6	AIR CHECK VALVE (OPTIONAL)
7	FLOW RATE CONTROL VALVE
8	PRESSURE GAUGE (OPTIONAL)
9	TEMPERATURE GAUGE (OPTIONAL)
10	HOSE REEL
11	CHECK VALVE
12	FILL NOZZLE
19	PRESET VALVE (OPTIONAL)

THIS DRAWING AND THE INFORMATION CONTAINED HEREIN ARE CONFIDENTIAL AND THE PROPERTY OF MURRAY EQUIPMENT, INC. THE DRAWING MAY NOT BE COPIED OR DISCLOSED TO OTHERS WITHOUT EXPRESS WRITTEN PERMISSION OF MURRAY EQUIPMENT, INC.

**CONDENSATE**  
**MOBILE LIQUID-MEASURING SYSTEM**

FOR  
 TOTAL CONTROL SYSTEMS  
 A DIVISION OF  
 MURRAY EQUIPMENT, INC.

DATE	08/16/06	DRAWING NUMBER	TC500112
REV.	SEP	REV.	

MURRAY EQUIPMENT, INC.

## LPG SYSTEM DESIGN

LPG will have a high vapor pressure and tends to vaporize easily. The successful meter operation will depend on the care exercised to prevent this from happening.

In order to prevent vaporization of LPG, certain elements must be adhered to in the design, fabricating and operation.

- 1) The piping from the storage tank to the pump inlet should be at least one pipe size larger than the pipe size of the pump inlet. Any valves, strainers or other fittings in the inlet piping system should be similarly sized. During operation the pressure at the pump inlet must be equal to or greater than the vapor pressure of the product.
- 2) All shut-off valves should be full-port ball type or similar free-flow type.
- 3) An external pump bypass (pressure relief) line from the pump outlet to the storage tank should be provided. This should include a pressure relief valve set to permit circulation through this line at a pressure that is about 25 PSI lower than the pump bypass relief valve setting. This is to prevent recirculation within the pump, which may cause heating and formation of vapor.
- 4) The piping system from the pump to the meter should be the same pipe size as the pump outlet. Shut-off valves should be the ball type or an equally free-flow type. A minimum number of elbows and fittings should be employed.
- 5) Safety valves or pressure relief valves should be included in the installation so that any section of the installation that might be isolated when valves are closed will be protected.
- 6) There must be provision for determining product temperature as it pass through the meter. The thermometer used should have no less than one graduation per degree F, preferably five.
- 7) Calibration of LPG flow meters should follow National Institute of Standards and Technology (NIST) Handbook 44 regulations pertaining to LPG.

LPG is flammable when mixed with air and the same safety precautions should be observed that would be used in handling a liquid such as gasoline. Dangerous concentrations of LPG may not be readily detected; therefore, adequate ventilation is a primary requirement.

LPG has a lighter coefficient of expansion than other petroleum liquids. A change in liquid temperature of 1 degree F will result in a change in volume of 0.17%. Due to this characteristic, it is common to use Automatic Temperature Compensators (ATC) on LPG meters used in the resale of LPG. The use of an ATC will automatically correct the delivered volume to 60 degrees F.



## METER CALIBRATION

The method of proving should be selected, and necessary provisions made, during the design stage of the installation. Of the most common used systems, portable provers have the advantage of more closely reproducing the condition under which the product is normally delivered.

Use this information for all flow meters, except on Liquefied Propane Gas (LPG) flow meters.

### **Use Accurate Prover**

Scientifically designed provers are commercially available for proving meters, and no other kind should be used. Even scientifically designed provers should be checked periodically for accuracy. Weights and Measures officials have been very cooperative in giving assistance to checking privately owned volumetric provers.

### Recommended size of test measure:

The prover capacity should be equal to at least one minute's flow through the meter at its maximum rate.

These provers are not merely truck compartments or drums, but are scientifically designed test measures, having proper drainage means built into them, a calibration gauge glass neck, and protection against deformation (which causes volume changes).

A "homemade" prover, whether a drum or a tank is not likely to be satisfactory, and may cause expensive errors due to inaccurate meter calibration.

### **Setting a Prover**

The prover should be set level, using the levels provided on the prover, or separate ones. This insures consistent results when moving the prover from meter to meter.

### **Where to Test a Meter**

The best place to test is in its normal operating position, instead of a test stand. In this way, the correctness of the installation and of the operation conditions will be verified by the test. Always test a meter with the same liquid it is to measure, because a difference in viscosity, temperature and system plumbing slightly affects meter accuracy.

### **Discharge Line from Meter**

Where a portable prover is used, the liquid is generally discharged in to the prover in the same manner, as a normal delivery would be made. Where a special test connection is used, the discharge line must be arranged to drain to the same point on each test. The meter flow rate and off/on is controlled at the end of the discharge line.

### **Wetting the Prover**

Reset the meter register to zero, and fill the prover to the zero or 100% marking of the scale. Disregard the meter reading. Drain the prover, and reset the register. The reason for disregarding the first meter reading is that the prover must be wetted, as its calibrated capacity is determined on its wet measure capacity by its manufacturer, and because the prover will be wet for the subsequent tests to be run.

After the prover has drained, allow a definitive time of a few minutes for drainage from the sides of the tank. Total drainage time should be the same between all tests to insure inform results. If a considerable length of time is to elapse between tests, the wetting operation can be eliminated by allowing the prover to remain full until the next test is to be run.

**Making the Tests**

The setup is now ready for the accuracy test. Reset the register to zero, and run the required tests through the meter. Do not exceed the maximum recommended rate of flow for the meter. Maximum and minimum recommended rates of flow for various sizes and types of 700 series meters are marked on their identification plates and maintenance manuals.

**Determining Test Results**

Run the meter to the mark on the dial corresponding to the prover capacity, and read the over or under delivery in cubic inches or percent on the calibrated plate on the neck of the prover. If the plate is calibrated in cubic inches, the percentage error can readily be computed on the following basis:

- (a) **One gallon equals 231cu.in.**
- (b) **A 100-gallon prover holds 23,100cu.in. Therefore, 23.1cu.in. represents 0.1% error.**

The National Institute of Standards and Technology, in its NIST Handbook 44 specifies a tolerance of plus or minus the following:

**METER TOLERANCE**

Indication of Device	Tolerance		
	Acceptance Test	Maintenance Test	Special Test
Wholesale	0.2%	0.3%	0.5%
Vehicle	0.15%	0.3%	0.45%

Acceptance tolerances apply to new meters and repaired meters after reconditioning.

**Repeatability**

When multiple tests are conducted at approximately the same flow rate and draft size, the range of test results for the flow rate shall not exceed 40% of the absolute value of the maintenance/normal tolerance and the results of each test shall be within the applicable tolerance.

**Changing Meter Calibration**

Refer to meter literature for method of changing meter calibration. Any change in the meter calibration adjustment will change the delivery in the same amount for all rates of flow. That is, the calibration curve retains its shape, but is moved up or down. Therefore, if a meter tests satisfactorily at full flow, but drops off too much at low flow, changing the calibration will not remedy this condition; it will bring the low flow test to 100%, but it will also bring the full flow above 100% by the same amount that the low flow was raised. A condition of this kind is caused either by the metering system, need for meter cleaning or repairs, or because of an attempt to retain accuracy below the minimum recommended rate of flow for the meter.

## **Temperature Correction**

If the conditions of testing are such that there will be a change of more than a few degrees in the temperature of the liquids between the time it passes through the meter and the time the prover is read, it will be advisable to make a temperature correction to the prover readings. To do this, it is necessary to install thermowells; to take readings of the temperature of the liquids in the meter and in the prover; and to take the degrees API of the liquid. Corrections can then be easily made by the use of the National Standard API Tables.

## **PRODUCT DEPLETION TEST (SPLIT COMPARTMENT)**

**Purpose:** A product depletion test verifies the proper operation of air elimination when the storage tank for the product being measured is pumped dry. This test is necessary for meters that may drain a tank completely, such as a vehicle tank meter.

### Multiple-Compartment Test Procedure:

1. Begin the test from a compartment (ideally the largest compartment) containing an amount of fuel equal to or less than one-half the nominal capacity of the prover being used. Operate the meter at the normal full flow rate until the compartment is empty. There are several methods for determining that the compartment is empty. There may be a significant change in the sound of the pump. There may be visual evidence that the compartment has run dry. The meter may stop entirely or may begin to move in jumps (pause, resume running, then pause, then run again.)
2. Continue the test until the meter indication stops entirely for at least 10 seconds. If the meter stops for 10 seconds or more, proceed to step 3. If the meter indication fails to stop entirely for a period of 10 seconds, continue to operate the system for 3 minutes.
3. Close the valve from the empty compartment, and if top filling, then close the nozzle or valve at the end of the delivery hose. Open the valve from another compartment containing the same product. Carefully open the valve at the end of the delivery hose. Pockets of vapor or air may cause product to splash out of the prover. The test results may not be valid if product is splashed out of prover. Appropriate attire and protection is required, but caution is still necessary.
4. Continue delivering product at the normal full flow rate until the liquid level in the prover reaches the nominal capacity of the prover.
5. Close the delivery nozzle or valve, stop the meter. Allow any foam to settle, then read the prover sight gauge as quickly as practical.
6. Compare the meter indication with the actual delivered volume in the prover.
7. Calculate the meter error, apply Product Depletion test tolerance, and determine whether or not the meter error is acceptable.

### Single Compartment Test Procedure:

The test of single-compartment tanks is easier to accomplish if there is a quick-connect hose coupling between the compartment valve and the pump that supplies product to the meter. If the system does not have quick-connect couplings between the compartment and the meter, an additional source of sufficient product at the test site is required.

Without a quick-connect coupling:

1. Begin the tests with the compartment containing an amount of fuel equal to or less than one-half the nominal capacity of the prover being used. Operate the meter at the normal full flow rate until the supply tank is empty. There are several methods for determining that the tank is empty. There may be significant change in the sound of the pump. Someone may visually watch for the tank to run dry. The meter may stop entirely or may begin to move in jumps (pause, resume running, the pause, then run again).
2. Continue the test until the meter indication stop entirely for at east 10 seconds. If the meter stops for at least 10 seconds, proceed to step 3. If the meter indication fails to stop entirely for at least 10 seconds, continue to operate the system for 3 minutes.
3. Close the compartment valve and the delivery nozzle or valve if top filling. Stop the pump and load sufficient product from the alternate source into the supple to compartment for the meter being tested. Allow the product to stand in the compartment for a brief time to allow entrained vapor or air to escape.
4. Open the compartment valve and restart the pump without pump resetting the meter to zero. Carefully open the nozzle of valve at the end of the delivery hose. Pockets of vapor or air may cause product to splash out of the prover. The test results may not be valid if product is splashed out of the prover. Appropriate eye protection is required, but caution is still necessary.
5. Continue delivery of product at the normal full flow rate until the liquid level in the prover reached the nominal capacity of the prover.
6. Close the delivery nozzle or valve, stop the meter, and allow any foam to settle, then read prover sight gauge.
7. Compare the meter indication with the actual delivered volume in the prover.
8. Calculate the meter error, apply Product Depletion test tolerance, and determine whether or not the meter error is acceptable.

With a quick-connect coupling:

1. During a normal full flow test run; close the compartment valve at approximately one-half of the nominal prover capacity. Then slowly and carefully disconnect the quick-connect coupling, allowing the pump to drain the supply line.
2. Continue the test until the meter indication stops entirely for at least 10 seconds. If the meter fails to stop entirely for at least 10 seconds, continue to operate the system for 3 minutes.
3. If the meter stops for at least 10 second or after 3 minutes, close the delivery nozzle or valve at the end of the delivery hose.
4. Disconnect and reconnect the quick-connect coupling and open the compartment valve.
5. Carefully open the nozzle or valve at the end of the delivery hose. Pockets of vapor or air may cause product to splash out of the prover. The test results may not be valid if product is splashed out of the prover.
6. Continue delivery of product at the normal full flow rate until the liquid level in the prover reaches the prover's nominal capacity.
7. Close the delivery nozzle or valve, stop the meter, allow any foam to settle, then read the prover sight gauge.
8. Compare the meter indication with the actual delivered volume in the prover.
9. Calculate the meter error, apply Product Depletion test tolerance, and determine whether or not the meter error is acceptable.

#### Tolerance for Vehicle-Tank Meters

Meter size	Maintenance and Acceptance
2" (50 mm)	137 cubic inches
3" (75 mm) and larger	229 cubic inches

The result of the product depletion test may fall outside of the applicable test tolerance, as this is a stand-alone test.

The test draft should be equal to at least the amount delivered by the device in 1 minute at its maximum discharge rate, and in no case should be less than 50 gallons.

## CALIBRATION PROCEDURE

- 1) Check for repeatability
  - A) Run a fast (high gallons per minute) test in your prover and record how much the meter is over or under registering. Do **NOT** change the meter's calibration.
  - B) Run a slow (low gallons per minute) test and again record how much the meter is over or under registration. If the results from the fast and the slow test are the same or close to the same, the meter can be successfully calibrated. If the test results differ beyond the rated tolerance of the meter, then repairs are necessary before the meter can be calibrated.
- 2) A valve or nozzle must be at the end of the delivery hose (at the prover).
- 3) Turn on the pump and purge the system of air. Leave the pump on.
- 4) Shut off the valve at the end of the delivery hose and let the system pressurize.
- 5) Wet the prover and empty it, letting it drip for 30 seconds.
- 6) Reset the register on the meter to "0".
- 7) Fill the prover to the line marked "0".
- 8) Calculate the percentage increase or decrease of registration required. For example, if a 50-gallon test prover indicates exactly 50 gallons have been run through the meter against a meter registration of 49.7 gallons, the percentage increase of registration would be 0.6%. ( $3/10$ 's in 50 gallons is 0.6%). If meter registration is less than the test prover measured volume, an increase adjustment is required. If meter registration is greater than the test prover measured volume, a decrease adjustment is required.
- 9) Remove the seal and seal wire.
- 10) Remove the front cover plate.
- 11) Loosen the screw on the clamping ring. The adjuster barrel will now be free to rotate.
- 12) Each small hash mark corresponds to 0.02% adjustment. Each of the larger numbers on the rotating barrel corresponds to 0.1%. The large numbers engraved into the adjuster body correspond to 1%. The entire range of adjustment is 5%, with the meter being set at the factory very close to the middle of this range.
- 13) To increase the registered volume, rotate the adjuster barrel to the left by the percentage increase desired. It is recommended that the barrel be rotated 0.02% more than the desired amount and then backed down to the desired figure. This accounts for any slack present in the adjuster mechanism. In the example above, the barrel would be rotated 16 tick marks on the barrel ( $15 \text{ tick marks} \times 0.02 = 0.3 = 3/10$ 's plus the one tick mark for slack). With the slack removed, the barrel would then be rotated one tick mark back to the right to achieve the final adjustment.
- 14) To decrease the registered volume, the adjuster barrel is rotated to the right.
- 15) Tighten the screw and clamping ring.
- 16) Run another test and adjust if necessary.
- 17) When calibration is achieved, ensure that the screw and clamping ring are tight, and then replace the cover plate.

One complete turn of the adjuster barrel is equal to 1 gallon in 100 gallons or 1% of delivered volume. The adjuster body will show divisions of 1%, while the adjuster barrel has divisions of 0.02%.

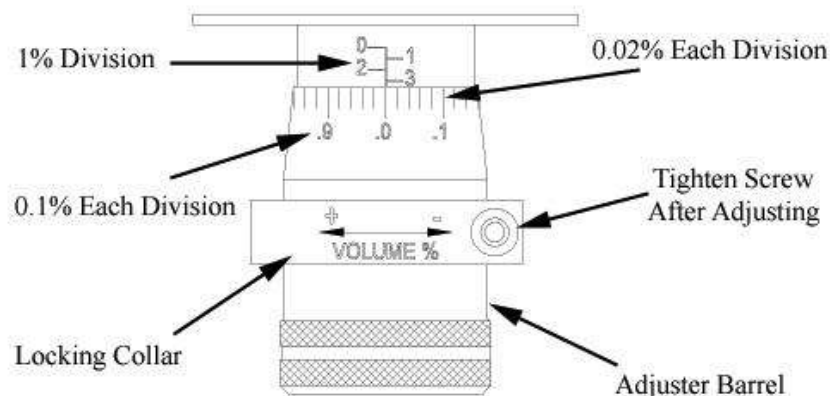

For volumes other than 100 gallons, the following formula may be used to calculate the Adjuster percent to increase or decrease prover volume.

$$\frac{\text{Volume on Prover minus Volume on the Meter Counter}}{\text{Volume on the Meter Counter}}$$

## DIRECTION OF FLOW

The meter is set up at the factory for left to right flow. To change the meter to right to left flow, begin by removing the screws (#9 on the Meter Assembly Breakdown in Service Manual) and the adjuster cover plate (#7) on the front of the meter. Remove both the screws (#1), the drive shaft retainer (#10), the bushings (#6), the drive shaft (#3), the e-ring (#4) and the face gear (#5). Reinstall the gear on the shaft with the gear teeth facing up. Snap the e-ring back into place to hold the gear in place. Reinstall the shaft, mating the face gear with the drive gear of the packing capsule assembly. Reinstall the screw and cover plate. The meter will now be set up for right to left flow.

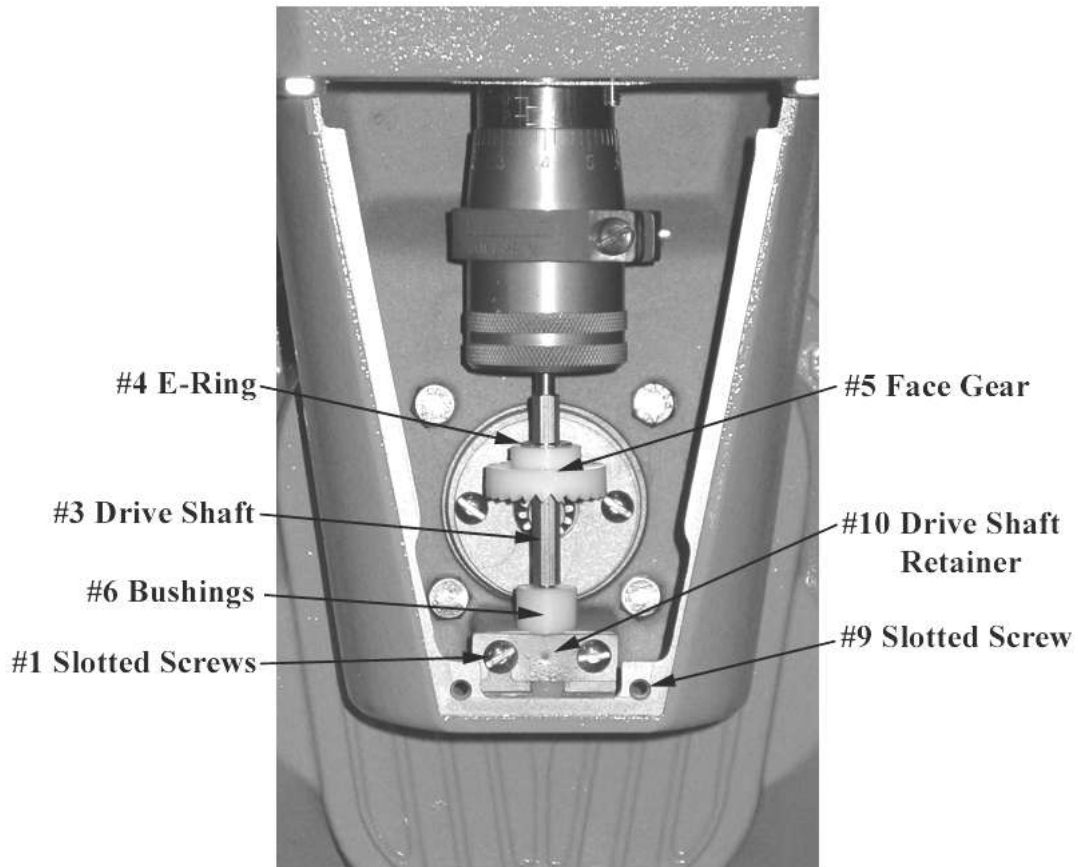

## 700 SERIES METER CONSTRUCTION

Type	Housing	Rotors	Journals	Bearing Sleeves*	Bearing Plates	Timing Gears	Packing Seal	Body/Flange O-rings	Internal Hardware
SP	Anodized Aluminum	Anodized Aluminum	Armolloy SS	Ni-Resist	Ni-Resist	Sintered SS	Viton®	Viton®	316 SS
SPA	Anodized Aluminum	Anodized Aluminum	Armolloy SS	Carbon Graphite	Ni-Resist	Sintered SS	Viton®	Viton®	316 SS
SPD	Ductile Iron	Ni-Resist	Armolloy SS	Carbon Graphite	Ni-Resist	Sintered SS	Simriz®	Teflon®	316 SS
LP	Anodized Aluminum	Anodized Aluminum	Armolloy SS	Carbon Graphite	Ni-Resist	Sintered SS	UL Buna N	UL Buna N	316 SS
IP	HC Anodized Aluminum	HC Anodized Aluminum	Armolloy SS	Illium 88 SS Alloy	17-4 SS	Sintered SS	Simriz®	Teflon®	316 SS
IC	HC Anodized Aluminum	HC Anodized Aluminum	Armolloy SS	Carbon Graphite	17-4 SS	Sintered SS	Simriz®	Teflon®	316 SS
AF	Ductile Iron	Ni-Resist	Armolloy SS	Carbon Graphite	316 SS	Sintered SS	Simriz®	Teflon®	316 SS
SS	316 SS	316 SS	Armolloy SS	Carbon Graphite	316 SS	316 SS	Simriz®	Teflon®	316 SS

\*Ceramic bearing sleeves available upon request.

Simriz is a registered trademark of Freudenberg-NOK.

Teflon is a registered trademark of Dupont Dow Elastomers, L.L.C.

Viton is a registered trademark of E.I. DuPont de Nemours & Co

## QUICK COMPATIBILITY

Product	Aluminum	Ductile Iron	Stainless Steel	Ni-Resist	Carbon Graphite	Ceramic	Buna-N	Viton	Simriz	Teflon
Acetone	■	■	■	■	■	■			■	■
Anhydrous Ammonia	■	■	■	■	■	■	■		■	■
Avgas	■	■	■	■	■	■	■	■	■	■
Bio-Diesel (B100)	■	■	■	■	■	■	■	■	■	■
Butane	■	■	■	■	■		■	■	■	■
Corn Syrup	■	■	■	■			■	■	■	■
Diesel Fuel	■	■	■	■	■	■	■	■	■	■
Epoxy	■	■	■	■					■	■
Ethanol	■	■	■	■	■	■	■	■	■	■
Fuel Oil	■	■	■	■	■	■	■	■	■	■
Gasoline	■	■	■	■	■	■	■	■	■	■
Glycerin	■	■	■	■	■	■	■	■	■	■
Jet Fuel	■	■	■	■	■	■	■	■	■	■
Kerosene	■	■	■	■	■	■	■	■	■	■
Latex	■		■				■	■	■	■
Liquefied Petroleum Gas	■	■	■	■	■		■	■	■	■
Methanol	■	■	■	■	■	■	■		■	■
Methyl Ethyl Ketone	■	■	■	■	■	■			■	■
Molasses	■	■	■	■	■	■	■	■	■	■
Naptha	■	■	■	■	■		■	■	■	■
Nitrogen Fertilizer	■	■	■	■	■	■	■	■	■	■
Nitric Acid (50%)						■			■	■
Paraffin	■	■	■	■			■	■	■	■
Potassium Carbonate		■	■	■	■		■	■	■	■
Rosins	■		■	■	■		■	■	■	■
Sodium Chloride			■		■		■	■	■	■
Stoddard Solvent	■	■	■	■	■	■	■	■	■	■
Tallow	■	■	■	■	■		■	■	■	■
Tetrachoroethylene		■	■	■	■	■	■	■	■	■
Urea			■		■	■		■	■	■
Varnish	■		■		■			■	■	■
Vegetable Oil	■	■	■	■	■	■	■	■	■	■
Water, Deionized					■	■	■	■	■	■
Xylene	■	■	■	■	■	■	■	■	■	■



SOLUTION	VISCOSITY SSU	SPECIFIC GRAVITY	700 ROTARY METER								
			SP	SPA	SPD	LP	IP	IC	AF	SS	
0-14-0, N-P-K SOLUTION			U	U	U	U	U	U	U	E	E
10-10-10, N-P-K SOLUTION			U	U	U	U	U	U	U	E	E
10-34-0, N-P-K SOLUTION			U	U	U	U	U	U	U	F	E
11-37-0, N-P-K SOLUTION			U	U	U	U	U	U	U	E	E
14-7-7, N-P-K SOLUTION			U	U	U	U	U	U	U	E	E
16-4-4, N-P-K SOLUTION			U	U	U	U	U	U	U	E	E
20-0-36, N-P-K SOLUTION			U	U	U	U	U	U	U	E	E
20-10-5, N-P-K SOLUTION			U	U	U	U	U	U	U	E	E
20-8-8, N-P-K SOLUTION			U	U	U	U	U	U	U	E	E
3-10-10, N-P-K SOLUTION			U	U	U	U	U	U	U	E	E
3-10-30, N-P-K SOLUTION			U	U	U	U	U	U	U	E	E
3-18-18, N-P-K SOLUTION			U	U	U	U	U	U	U	E	E
3-9-12, N-P-K SOLUTION			U	U	U	U	U	U	U	G	E
3-9-9, N-P-K SOLUTION			U	U	U	U	U	U	U	G	E
4-12-12, N-P-K SOLUTION			U	U	U	U	U	U	U	E	E
4-12-8, N-P-K SOLUTION			U	U	U	U	U	U	U	G	E
5-15-15, N-P-K SOLUTION			U	U	U	U	U	U	U	E	E
5-8-12, N-P-K SOLUTION			U	U	U	U	U	U	U	E	E
6-18-6, N-P-K SOLUTION			U	U	U	U	U	U	U	E	E
7-12-6, N-P-K SOLUTION			U	U	U	U	U	U	U	E	E
9-18-9, N-P-K SOLUTION			U	U	U	U	U	U	U	E	E
AATREX®, HERBICIDE		1.19	U	U	U	U	F	U	U	E	E
ACETALDEHYDE		0.783	U	U	U	U	G	G	G	G	E
ACETATE		0.9	U	U	U	U	G	G	G	G	E
ACETIC ACID	30	1.05	U	U	U	U	U	U	U	U	G
ACETIC ANHYDRITE		1.09	U	U	U	U	U	U	U	U	E
ACETONE	30	0.8	U	U	U	U	G	G	G	G	E
ACETYL CHLORIDE		1.11	U	U	U	U	U	U	U	G	E
ACRYLIC ACID	40	1.05	U	U	U	U	G	G	G	G	E
ACRYLIC ADHESIVES			U	U	U	U	G	G	G	G	E
ACRYLIC EMULSION			U	U	U	U	G	G	G	G	E
ACRYLIC ESTER			U	U	U	U	G	G	G	G	E
ACRYLIC RESIN			U	U	U	U	G	G	G	G	E
ACRYLONITRILE	100	0.8	U	U	U	U	G	G	G	G	E
ADBLUE			U	U	F	U	U	U	U	F	E
ADHESIVES			U	U	U	U	G	G	G	G	G
AIR (LIQUID CRYOGENIC)			U	U	U	U	U	U	U	U	U
ALCOHOL			U	U	G	U	U	G	G	G	E
ALCOHOL, ALLYL		0.852	U	U	U	U	U	U	U	U	E
ALCOHOL, AMYL		0.817	U	U	G	U	F	G	G	G	E
ALCOHOL, BEER (NOT SANITARY)	32	1.01	U	U	U	U	U	U	U	U	G
ALCOHOL, BENZYL		1.04	U	U	G	U	F	G	G	G	E
ALCOHOL, BUTYL		0.8109	U	U	G	U	F	G	G	G	E
ALCOHOL, DENATURED			U	U	G	U	F	G	G	G	E
ALCOHOL, DIACETONE		0.94	U	U	G	U	F	G	G	G	E
ALCOHOL, ETHYL	30	0.816	U	G	E	U	U	G	G	G	E
ALCOHOL, ETHYLENE		1.115	U	F	E	U	U	G	G	G	E
ALCOHOL, ISOBUTYL		0.806	U	U	G	U	F	G	G	G	E
ALCOHOL, ISOPROPYL		0.7863	G	U	G	U	F	G	G	G	E
ALCOHOL, METHYL	30	0.79	U	U	E	U	U	G	G	G	E
ALCOHOL, POLYVINYL	5000 - 50000	1.31	U	U	G	U	F	G	G	G	E

**E = Excellent / Recommended**  
**G = Good / Minor Effect**  
**F = Fair / Moderate Effect**  
**U = Not Recommended**

This chart is intended as a chemical resistance guide rather than an unconditional rating since many system characteristics influence rate of corrosion and operation of meter; such as solution, viscosity, concentration, temperature, lubricity, presence of solids, pressure and flow rate. Ratings apply to liquids and solutions of commercial purity. Ratings do not imply Weights & Measures or UL conformance. Ratings for food type materials do not imply FDA conformance. Information compiled is based on published data and research performed by Total Control Systems. Total Control Systems cannot warranty, expressed or implied, that the laboratory results would be obtained under actual operating conditions.

SOLUTION	VISCOSITY SSU	SPECIFIC GRAVITY	700 ROTARY METER							
			SP	SPA	SPD	LP	IP	IC	AF	SS
ALCOHOL, PROPYL		0.804	G	U	G	U	F	G	G	E
ALCOHOL, WHISKEY (NOT SANITARY)	150		U	U	U	U	U	U	U	E
ALCOHOL, WINE (NOT SANITARY)			U	U	U	U	U	U	U	E
ALKALI SOLUTION			U	U	U	U	U	U	G	E
ALKYD RESINS	50000		U	U	U	U	G	G	G	E
ALUMINUM CHLORIDE		2.44	U	U	U	U	U	U	U	U
ALUMINUM HYDROXIDE (10%)		2.42	U	U	U	U	U	U	U	E
ALUMINUM NITRATE			U	U	U	U	U	U	U	E
ALUMINUM SULFATE (50%, 125F)		2.71	U	U	U	U	U	U	U	F
AMINES			U	U	U	U	U	U	G	F
AMMONIA (32%)		0.99	U	U	U	U	U	U	G	E
AMMONIA, ANHYDROUS (NH3) (USE TEFLON SEALS & COUNTER EXTENSION)	30	0.70	U	U	U	G	U	U	U	U
AMMONIUM CARBONATE			U	U	U	U	U	U	G	E
AMMONIUM CHLORIDE	50	1.05	U	U	U	U	U	U	U	G
AMMONIUM HYDROXIDE	30	0.99	U	U	U	U	U	G	G	E
AMMONIUM NITRATE		1.73	U	U	U	U	G	G	F	E
AMMONIUM PHOSPHATE	50	1.62	U	U	U	U	U	U	U	F
AMMONIUM SULFATE		1.77	U	U	U	U	U	U	U	G
AMMONIUM SULFIDE			U	U	U	U	U	U	U	U
AMMONIUM SULFITE		1.41	U	U	U	U	U	U	U	U
AMYL ACETATE	30	0.88	U	U	U	U	U	G	G	G
ANILINE	40	1.02	U	U	U	U	U	U	G	E
ANIMAL FAT			U	U	U	U	U	U	G	E
ANITIFREEZE	88	1.10	E	E	E	U	E	E	E	E
ANTIMONY TRICHLORIDE			U	U	U	U	U	U	U	U
APPLE JUICE (NOT SANITARY)		1.06	U	U	U	U	U	U	U	E
AQUA AMMONIA			U	U	U	U	U	U	G	E
AQUA REGIA			U	U	U	U	U	U	U	U
AROMATIC SOLVENTS			U	U	E	U	E	E	E	E
ARSENIC ACID	50	2.0	U	U	U	U	U	U	U	G
ASPHALT (120F - 300F) (USE HEAT EXTENSION & TRIM)	2400 - 12000	1.1 - 1.5	U	U	U	U	G	U	G	E
ASPHALT EMULSION (75F) (WATER BASED MAY CONTAIN CLAY)	155 - 7000	1.0	U	U	U	U	G	U	G	E
AVIATION GASOLINE (AV GAS)	30	0.71	U	E	E	U	U	E	G	E
BACKDRAFT®, HERBICIDE			U	U	U	U	U	U	G	E
BIARIUM HYDROXIDE		1.65	U	U	U	U	U	U	G	G
BIARIUM NITRATE		3.24	U	U	U	U	U	U	F	E
BIARIUM SULFATE			U	U	U	U	U	U	F	E
BIARIUM SULFIDE		4.25	U	U	U	U	U	U	F	G
BARRICADE®, INSECTICIDE			U	U	U	U	U	U	E	E
BASAGRAN®, HERBICIDE			U	U	U	U	U	F	E	E
BEER	32	1.0	U	U	U	U	U	U	U	G
BEET SUGAR LIQUIDS			U	U	U	U	E	U	G	E
BENZALDEHYDE	40	1.05	U	U	U	U	U	G	G	E
BENZENE	31	0.90	U	U	U	U	F	G	G	G
BENZOIC ACID		1.27	U	U	U	U	G	G	U	G
BENZOL		1.04	U	U	U	U	G	G	G	G
BENZYL CHLORIDE		1.10	U	U	U	U	U	U	U	F
BICEP®, HERBICIDE			U	U	U	U	F	F	E	E
BIODIESEL FUEL (B100 @ 70F)	38	0.88	E	E	E	U	E	E	E	E

**E = Excellent / Recommended**  
**G = Good / Minor Effect**  
**F = Fair / Moderate Effect**  
**U = Not Recommended**

This chart is intended as a chemical resistance guide rather than an unconditional rating since many system characteristics influence rate of corrosion and operation of meter; such as solution, viscosity, concentration, temperature, lubricity, presence of solids, pressure and flow rate. Ratings apply to liquids and solutions of commercial purity. Ratings do not imply Weights & Measures or UL conformance. Ratings for food type materials do not imply FDA conformance. Information compiled is based on published data and research performed by Total Control Systems. Total Control Systems cannot warranty, expressed or implied, that the laboratory results would be obtained under actual operating conditions.

SOLUTION	VISCOSITY SSU	SPECIFIC GRAVITY	700 ROTARY METER							
			SP	SPA	SPD	LP	IP	IC	AF	SS
BIPHENYL		1.0	U	U	U	U	G	G	G	E
BLEACH SOLUTION			U	U	U	U	U	U	U	U
BORAX	50	1.73	U	U	U	U	U	U	U	G
BOUNDARY®, HERBICIDE			U	U	U	U	F	F	E	E
BRAVO®, FUNGICIDE			U	U	U	U	U	U	G	E
BRINE SOLUTION			U	U	U	U	U	U	F	G
BROADSTRIKE™, HERBICIDE			U	U	U	U	F	F	E	E
BROMINE		3.11	U	U	U	U	U	U	U	U
BUCTRIL®, HERBICIDE			U	U	U	U	F	F	E	E
BUTADIENE (USE VITON OR TEFLON SEALS)	50	0.62	U	U	U	E	F	G	F	E
BUTANE	30	0.60	U	U	U	E	U	U	U	U
BUTANOL	30	0.81	U	U	U	G	U	G	G	E
BUTYL ACETATE	30	0.88	U	U	U	U	F	G	G	E
BUTYL ACRYLATE	50	0.90	U	U	U	U	F	G	U	G
BUTYL CARBITOL		0.95	U	U	U	U	F	G	G	E
BUTYL CELLOSOLVE	50	0.90	U	U	U	U	F	G	G	E
BUTYL PHTHALATE		1.05	U	U	U	U	F	G	G	E
BUTYLENE		0.60	U	U	U	E	F	G	G	E
CALCIUM CHLORIDE	50	1.23	U	U	U	U	U	U	F	G
CALCIUM HYDROXIDE		2.34	U	U	U	U	U	U	G	E
CALCIUM HYPOCHLORITE			U	U	U	U	U	U	U	U
CANE SUGAR LIQUIDS	225 - 5000		U	U	U	U	G	U	G	G
CAMIX®, HERBICIDE			U	U	U	U	U	U	U	G
CARBITOL		0.95	U	U	U	U	F	G	G	G
CARBON DIOXIDE			U	U	U	U	U	U	U	U
CARBON TETRACHLORIDE	30	1.59	U	U	U	U	F	U	F	G
CARMEL (NOT SANITARY)	1950		U	U	U	U	U	U	U	E
CATTLE FEED			U	U	U	U	U	U	G	E
CAUSTIC POTASH			U	U	U	U	U	U	G	E
CAUSTIC SODA (50%, 125F)	150	1.53	U	U	U	U	U	U	G	G
CELLOSOLVE		0.90	U	U	U	U	F	G	G	E
CHLORACETIC ACID		1.58	U	U	U	U	U	U	U	U
CHLORIC ACID			U	U	U	U	U	U	U	U
CHLORINATED SOLVENTS			U	U	U	U	U	U	G	G
CHLORINE			U	U	U	U	U	U	U	U
CHLOROBENZENE	30	1.10	U	U	U	U	U	U	G	E
CHLOROETHENE		0.91	U	U	U	U	U	U	G	E
CHLOROFORM		1.49	U	U	U	U	U	U	G	E
CHLOROPRENE		0.96	U	U	U	U	U	U	U	U
CHLOROSULPHONIC ACID		1.76	U	U	U	U	U	U	U	U
CHLOROTHENE			U	U	U	U	U	U	G	E
CHOCOLATE (NOT SANITARY)	50000 - 100000		U	U	U	U	G	U	U	E
CHOLINE CHLORIDE			U	U	U	U	U	U	U	G
CHROMIC ACID		2.67	U	U	U	U	U	U	U	U
CHROMIUM SULFATE		1.70	U	U	U	U	U	U	U	G
CIDER (NOT SANITARY)			U	U	U	U	U	U	U	E
CITRIC ACID (30%, 75F)	50	1.54	U	U	U	U	U	U	U	E
CLARITY®, HERBICIDE			U	U	U	U	F	F	E	E
COAL TAR EMULSION	3000 - 8000	1.2	U	U	U	U	G	F	F	G
COBALT NITRATE (COBALTOUS)		1.88	U	U	U	U	U	U	U	G
COCOA BUTTER		0.86	U	U	U	U	G	U	F	E

**E = Excellent / Recommended**  
**G = Good / Minor Effect**  
**F = Fair / Moderate Effect**  
**U = Not Recommended**

This chart is intended as a chemical resistance guide rather than an unconditional rating since many system characteristics influence rate of corrosion and operation of meter; such as solution, viscosity, concentration, temperature, lubricity, presence of solids, pressure and flow rate. Ratings apply to liquids and solutions of commercial purity. Ratings do not imply Weights & Measures or UL conformance. Ratings for food type materials do not imply FDA conformance. Information compiled is based on published data and research performed by Total Control Systems. Total Control Systems cannot warranty, expressed or implied, that the laboratory results would be obtained under actual operating conditions.

SOLUTION	VISCOSITY SSU	SPECIFIC GRAVITY	700 ROTARY METER							
			SP	SPA	SPD	LP	IP	IC	AF	SS
COMMAND®, HERBICIDE			U	U	U	U	F	F	E	E
COPPER CHLORIDE		3.38	U	U	U	U	U	U	U	U
COPPER CYANIDE			U	U	U	U	U	U	U	U
COPPER NITRATE	50	2.17	U	U	U	U	U	U	U	G
COPPER SULFATE	50	2.28	U	U	U	U	U	U	U	G
CORN EXTRACTIVE, FERMENTED	10000	1.20	U	U	U	U	G	G	G	E
CORN STARCH	150 - 1400	1.20	U	U	U	U	U	U	U	U
CORN SYRUP (NOT SANITARY)	5000 - 500000	1.35	U	U	U	U	G	U	G	E
CORNSWEET (NOT SANITARY)	740	1.35	U	U	U	U	G	U	G	E
COTTONQUICK®, DEFOLIANT			U	U	U	U	U	U	U	E
CRANBERRY JUICE (NOT SANITARY)			U	U	U	U	U	U	U	E
CREOSOTE (COAL TAR)	300	1.08	U	U	U	U	G	F	F	G
CRESYLIC ACID (CRESOL)			U	U	U	U	U	U	U	G
CROP OILS	100	1.04	G	G	E	U	G	G	E	E
CUMENE		0.86	U	U	U	U	F	G	G	E
CUTTING OILS			E	E	E	U	E	E	E	E
CYCLOHEXANE	50	0.78	U	U	U	U	F	G	G	E
CYCLOHEXANOL		0.94	U	U	U	U	F	G	G	E
CYCLOHEXANONE		0.94	U	U	U	U	F	G	G	G
CYCLONE® MAX, HERBICIDE			U	U	U	U	U	U	U	E
DEF®, DEFOLIANT			U	U	U	U	U	U	U	E
DEICING FLUID		1.15	G	G	G	G	G	G	G	G
DETERGENTS		1.20	U	U	U	U	U	U	G	E
DEXTROSE			U	U	U	U	G	U	U	E
DIAZINON, INSECTICIDE			U	U	U	U	U	U	E	E
DIBUTYL PHTHALATE			U	U	U	U	F	G	G	E
DICHLOROBENZENE		1.46	U	U	U	U	U	U	G	G
DICHLOROETHANE		1.26	U	U	U	U	U	U	G	G
DICHLOROPROPENE		1.23	U	U	U	U	U	U	G	E
DIESEL FUEL (LOW SULPHUR)	30 - 100	0.90	E	E	E	U	E	E	E	E
DIETHANOLAMINE		1.10	U	U	U	U	F	G	G	G
DIETHYL SULFATE		1.18	U	U	U	U	F	G	G	G
DIETHYLANILINE		0.96	U	U	U	U	F	G	G	E
DIETHYLBENZENE		0.865	U	U	U	U	F	G	G	G
DIETHYLENE GLYCOL		1.12	U	U	U	U	F	G	G	E
DIISOBUTYL KETONE		0.81	U	U	U	U	F	G	G	E
DIISOCYANATE			U	U	U	U	U	U	F	G
DIISOPROPYL KETONE			U	U	U	U	F	G	G	E
DIMETHYLAMINE		0.69	U	U	U	U	F	G	G	E
DIMETHYLFORMAMIDE		0.95	U	U	U	U	F	G	G	G
DIOCTYL PHTHALATE	320	0.99	U	U	U	U	F	G	G	G
DIPHENYL		1.0	U	U	U	U	F	G	G	G
DIPHENYL OXIDE		1.74	U	U	U	U	F	G	G	E
DIPROPYLENE GLYCOL		1.03	G	G	G	U	G	G	G	G
DIVINYLBENZENE		0.93	U	U	U	U	F	G	G	E
DOUBLEPLAY®, HERBICIDE			U	U	U	U	F	F	E	E
DOW THERM			E	E	E	U	E	E	E	E
DUAL®, HERBICIDE			U	U	U	U	F	F	E	E
DYE			U	U	U	U	U	U	U	E
EDTA			U	U	U	U	U	U	F	G
E-85		0.78	F	G	E	U	U	G	E	E

**E = Excellent / Recommended**  
**G = Good / Minor Effect**  
**F = Fair / Moderate Effect**  
**U = Not Recommended**

This chart is intended as a chemical resistance guide rather than an unconditional rating since many system characteristics influence rate of corrosion and operation of meter; such as solution, viscosity, concentration, temperature, lubricity, presence of solids, pressure and flow rate. Ratings apply to liquids and solutions of commercial purity. Ratings do not imply Weights & Measures or UL conformance. Ratings for food type materials do not imply FDA conformance. Information compiled is based on published data and research performed by Total Control Systems. Total Control Systems cannot warranty, expressed or implied, that the laboratory results would be obtained under actual operating conditions.

SOLUTION	VISCOSITY SSU	SPECIFIC GRAVITY	700 ROTARY METER							
			SP	SPA	SPD	LP	IP	IC	AF	SS
EMULSION			G	G	G	U	G	G	G	E
ENAMEL			U	U	U	U	G	G	G	E
EPOXY	46500	1.15	U	U	U	U	G	G	G	G
EPOXY RESIN			U	U	U	U	G	G	G	G
EPTAM®, HERBICIDE			U	U	U	U	F	F	E	E
ETHANE		0.45	U	U	U	E	U	U	U	U
ETHANOL	30	0.79	U	G	E	U	U	G	E	E
ETHANOLAMINE		1.02	U	U	U	U	F	G	G	E
ETHER		0.69	U	U	U	U	U	F	G	G
ETHYL ACETATE	30	0.89	U	U	U	U	F	G	G	G
ETHYL ACRYLATE		0.92	U	U	U	U	U	U	U	E
ETHYL HEXANOIC ACID		0.91	U	U	U	U	U	U	U	G
ETHYLAMINE		0.69	U	U	U	U	U	F	F	G
ETHYLBENZENE		0.87	U	U	U	U	F	G	G	E
ETHYLENE CHLORIDE	30	1.26	U	U	U	U	U	U	G	E
ETHYLENE DIAMINE	30	0.90	U	U	U	U	U	U	G	E
ETHYLENE DIBROMIDE		2.17	U	U	U	U	U	U	U	E
ETHYLENE DICHLORIDE	30	1.26	U	U	U	U	U	U	G	E
ETHYLENE GLYCOL	100	1.12	E	E	E	U	E	E	E	E
ETHYLENE OXIDE	30	0.87	U	U	U	U	U	U	U	U
ETHYLENE VINYL ACETATE	7000		U	U	U	U	U	U	U	E
EXTREME®, HERBICIDE			U	U	U	U	U	U	G	E
FATTY ACIDS		0.84	U	U	U	U	F	F	F	E
FERRIC CHLORIDE		2.80	U	U	U	U	U	U	U	U
FERRIC HYDROXIDE		3.40	U	U	U	U	U	U	U	U
FERRIC NITRATE		1.68	U	U	U	U	U	U	U	G
FERRIC SULFATE	50	2.10	U	U	U	U	U	U	U	G
FERROUS CHLORIDE		1.93	U	U	U	U	U	U	U	U
FERROUS SULFATE		1.90	U	U	U	U	U	U	U	G
FINISH HARVEST AID			U	U	U	U	U	U	U	G
FLUORINE			U	U	U	U	U	U	U	U
FLUOSILIC ACID			U	U	U	U	U	U	U	U
FORMALDEHYDE	30	0.82	U	U	U	U	F	F	U	G
FORMIC ACID		1.22	U	U	U	U	U	U	U	F
FREEDOM®, HERBICIDE			U	U	U	U	F	F	E	E
FREON® 11	< 30	1.48	U	U	U	G	U	U	U	U
FREON® 12	< 30	1.31	U	U	U	G	U	U	U	U
FREON® 13			U	U	U	G	U	U	U	U
FREON® 14			U	U	U	G	U	U	U	U
FREON® 21 (USE TEFLON SEALS)	< 30	1.37	U	U	U	G	U	U	U	U
FREON® 22(USE TEFLON SEALS)	< 30	1.12	U	U	U	G	U	U	U	U
FREON® 31 (USE TEFLON SEALS)			U	U	U	G	U	U	U	U
FREON® 112 (USE TEFLON SEALS)	< 30	1.63	U	U	U	G	U	U	U	U
FREON® 113	< 30	1.57	U	U	U	G	U	U	U	U
FREON® 114	< 30	1.46	U	U	U	G	U	U	U	U
FREON® 114B2 (USE TEFLON SEALS)	< 30	2.16	U	U	U	G	U	U	U	U
FREON® 115	< 30	1.29	U	U	U	G	U	U	U	U
FREON® 134A (USE TEFLON SEALS)	< 30	1.21	U	U	U	G	U	U	U	U
FRONTIER®, HERBICIDE			U	U	U	U	F	F	E	E
FUEL OIL #1	34	0.85	E	E	E	U	E	E	E	E
FUEL OIL #2	36	0.87	E	E	E	U	E	E	E	E

**E = Excellent / Recommended**  
**G = Good / Minor Effect**  
**F = Fair / Moderate Effect**  
**U = Not Recommended**

This chart is intended as a chemical resistance guide rather than an unconditional rating since many system characteristics influence rate of corrosion and operation of meter; such as solution, viscosity, concentration, temperature, lubricity, presence of solids, pressure and flow rate. Ratings apply to liquids and solutions of commercial purity. Ratings do not imply Weights & Measures or UL conformance. Ratings for food type materials do not imply FDA conformance. Information compiled is based on published data and research performed by Total Control Systems. Total Control Systems cannot warranty, expressed or implied, that the laboratory results would be obtained under actual operating conditions.

SOLUTION	VISCOSITY SSU	SPECIFIC GRAVITY	700 ROTARY METER							
			SP	SPA	SPD	LP	IP	IC	AF	SS
FUEL OIL #3		0.9	E	E	E	U	E	E	E	E
FUEL OIL #4	105	0.95	E	E	E	U	E	E	E	E
FUEL OIL #6	2000 – 10000	0.97	E	E	E	U	E	E	E	E
FULTIME®, HERBICIDE	1280	1.16	U	U	U	U	F	F	E	E
FURAN RESIN		0.94	U	U	U	U	G	F	G	E
FURFURAL	50	1.16	U	U	U	U	F	G	G	G
GALAXY®, HERBICIDE			U	U	U	U	F	F	E	E
GASOHOL	30	0.72	F	E	E	U	F	E	E	E
GASOLINE	33	0.75	E	E	E	U	E	E	E	E
GLUCOSE	50000	1.40	U	U	U	U	G	U	G	E
GLUE			U	U	U	U	G	F	G	E
GLYCERIN (GLYCEROL)	5000	1.26	G	G	E	U	G	G	G	E
GLYCOL	50 - 200	1.11	E	E	E	U	E	E	E	E
GLYCOL ESTER			U	G	G	U	G	G	G	E
GLYPHOMAX® PLUS, HERBICIDE			U	U	U	U	U	U	G	G
GRAMOXONE® EXTRA, HERBICIDE			U	U	U	U	U	U	U	E
GRAZON®, HERBICIDE			U	U	U	U	F	F	E	E
GREASE			E	E	E	U	E	E	E	E
GUARDSMAN®, HERBICIDE			U	U	U	U	F	F	E	E
HARNESS®, HERBICIDE			U	U	U	U	F	F	E	E
HEPTANE	30	0.70	U	U	U	U	U	G	G	E
HEXANE	30	0.66	U	U	U	U	U	G	G	E
HYDROCARBON RESIN			U	U	U	U	U	G	G	E
HYDROCHLORIC ACID			U	U	U	U	U	U	U	U
HYDROGEN PEROXIDE			U	U	U	U	U	U	U	U
INK (CAN BE ABRASIVE)	500 - 50000	1.0 – 1.4	U	U	U	U	F	F	F	G
IODINE		4.98	U	U	U	U	U	U	U	U
ISOBUTYL ACETATE		0.87	U	U	U	U	F	G	G	E
ISOBUTYL KETONE			U	U	U	U	F	G	G	E
ISOCYANATE		1.20	U	U	U	U	F	G	G	E
ISOOCTANE		0.69	G	G	G	U	F	G	G	E
ISOPROPYL ACETATE	30	0.87	U	U	U	U	F	G	G	E
ISOPROPYL ETHER	30	0.72	U	U	U	U	F	G	G	E
JET FUEL	30	0.80	G	E	U	U	E	E	U	E
KEROSENE	34	0.81	E	E	E	U	E	E	E	E
KETCHUP (NOT SANITARY)			U	U	U	U	U	U	U	E
KETONES			U	U	U	U	U	G	G	E
LACQUER	100 - 100000	0.95	U	U	U	U	G	G	G	E
LACTIC ACID		1.20	U	U	U	U	U	U	U	G
LACTOL SPIRITS			G	G	G	U	F	G	G	E
LADDOK®, HERBICIDE			U	U	U	U	F	F	E	E
LANOLIN			U	U	U	U	G	G	G	E
LARD		0.95	U	U	U	U	G	U	G	E
LASSO®, HERBICIDE			U	U	U	U	F	F	E	E
LATEX (CONGEALS & SHEAR SENSITIVE)	15000		U	U	U	U	G	G	G	E
LATEX EMULSIONS (SHEAR SENSITIVE)	10000 - 100000		U	U	U	U	G	G	G	E
LEAD ACETATE		2.50	U	U	U	U	U	U	U	G
LEMON JUICE			U	U	U	U	U	U	U	E
LIBERTY®, HERBICIDE			U	U	U	U	F	F	E	E
LIGNUM SULFONATE	10000	1.20	G	G	G	U	F	G	G	E
LIME WATER		2.34	U	U	U	U	U	U	G	E

**E = Excellent / Recommended**  
**G = Good / Minor Effect**  
**F = Fair / Moderate Effect**  
**U = Not Recommended**

This chart is intended as a chemical resistance guide rather than an unconditional rating since many system characteristics influence rate of corrosion and operation of meter; such as solution, viscosity, concentration, temperature, lubricity, presence of solids, pressure and flow rate. Ratings apply to liquids and solutions of commercial purity. Ratings do not imply Weights & Measures or UL conformance. Ratings for food type materials do not imply FDA conformance. Information compiled is based on published data and research performed by Total Control Systems. Total Control Systems cannot warranty, expressed or implied, that the laboratory results would be obtained under actual operating conditions.

SOLUTION	VISCOSITY SSU	SPECIFIC GRAVITY	700 ROTARY METER							
			SP	SPA	SPD	LP	IP	IC	AF	SS
LIQUID FEED (CAUSTIC)			U	U	U	U	U	U	U	E
LIQUID FEED (NEUTRAL)			U	U	U	U	U	U	G	E
LIQUIFIED NATURAL GAS (LNG)			U	U	U	U	U	U	U	U
LIQUIFIED PETROLEUM GAS (LPG)	30	0.50	U	U	U	E	U	U	U	U
LORSBAN® 4E, INSECTICIDE			U	U	U	U	U	U	E	E
LUMAX®, HERBICIDE			U	U	U	U	U	U	U	G
MAGNESIUM CHLORIDE		2.32	U	U	U	U	U	U	U	F
MAGNESIUM HYDROXIDE		2.36	U	U	U	U	U	U	G	E
MAGNESIUM NITRATE		1.46	U	U	U	U	U	U	U	G
MAGNESIUM SULFATE	50	1.68	U	U	U	U	F	F	F	G
MALATHION		1.23	U	U	U	U	F	F	E	E
MALEIC ACID		1.59	U	U	U	U	U	U	U	E
MALEIC ANHYDRIDE		1.30	U	U	U	U	U	U	U	G
MANEX®, FUNGICIDE			U	U	U	U	U	U	G	E
MARKSMAN®, HERBICIDE			U	U	U	U	F	F	E	E
MAYONNAISE (NOT SANITARY)	9400		U	U	U	U	U	U	U	E
METHANE			U	U	U	U	U	U	U	U
METHANOL	30	0.79	U	U	E	U	U	G	G	E
METHYL ACETATE		0.92	U	U	U	U	F	G	G	E
METHYL BROMIDE		1.73	U	U	U	U	U	U	F	G
METHYL CELLOSOLVE		0.97	U	U	U	U	F	G	G	E
METHYL CHLORIDE		0.92	U	U	U	U	U	U	U	G
METHYL CHLOROFORM		1.33	U	U	U	U	U	U	G	E
METHYL ETHYL KETONE (MEK)	30	0.82	U	U	U	U	U	G	G	E
METHYL ISOBUTYL KETONE	30	0.80	U	U	U	U	U	G	G	G
METHYL METHACRYLATE	30	0.95	U	U	U	U	F	G	F	E
METHYL PARATHION			U	U	U	U	F	F	E	E
METHYLENE CHLORIDE		0.92	U	U	U	U	U	U	U	G
METHYL-T-BUTYL ETHER (MTBE)	30	0.74	F	G	G	U	U	G	G	E
MICRO-NUTRIENTS (CAUSTIC)			U	U	E	U	U	U	U	E
MICRO-NUTRIENTS (NEUTRAL)			U	G	E	U	U	U	G	E
MINERAL SPIRITS			E	E	E	U	E	E	E	E
MOLASSES (CAUSTIC)	1000 - 100000	1.45	U	U	E	U	U	U	U	E
MOLASSES (NEUTRAL)	1000 - 100000	1.45	U	G	E	U	U	U	G	E
MONOCHLOROACETIC ACID			U	U	U	U	U	U	U	U
MONOCHLOROBENZENE		1.11	U	U	U	U	U	U	G	E
MONOETHANOLAMINE		0.69	U	U	U	U	U	U	G	E
MONOETHYLAMINE		0.69	U	U	U	U	U	U	G	E
MONOMERS			G	G	G	U	G	G	G	E
MURIATIC ACID			U	U	U	U	U	U	U	U
NAPHTHA	30	0.89	E	E	E	U	E	E	E	E
NAPHTHALENE		1.15	U	U	E	U	U	U	G	E
NAPHTHENIC ACID			U	U	U	U	U	U	F	E
NATURAL GASOLINE			U	F	E	U	U	F	E	E
NEOPENTYL GLYCOL		1.07	U	U	U	U	G	G	G	E
NICKEL AMMONIUM SULFATE			U	U	U	U	U	U	U	U
NICKEL CHLORIDE		3.55	U	U	U	U	U	U	U	G
NICKEL NITRATE		2.07	U	U	U	U	U	U	U	G
NICKEL SULFATE		2.0	U	U	U	U	U	U	U	G
NITRIC ACID			U	U	U	U	U	U	U	U
NITROBENZENE	30	1.20	U	U	U	U	G	G	G	E

**E = Excellent / Recommended**  
**G = Good / Minor Effect**  
**F = Fair / Moderate Effect**  
**U = Not Recommended**

This chart is intended as a chemical resistance guide rather than an unconditional rating since many system characteristics influence rate of corrosion and operation of meter; such as solution, viscosity, concentration, temperature, lubricity, presence of solids, pressure and flow rate. Ratings apply to liquids and solutions of commercial purity. Ratings do not imply Weights & Measures or UL conformance. Ratings for food type materials do not imply FDA conformance. Information compiled is based on published data and research performed by Total Control Systems. Total Control Systems cannot warranty, expressed or implied, that the laboratory results would be obtained under actual operating conditions.

SOLUTION	VISCOSITY SSU	SPECIFIC GRAVITY	700 ROTARY METER							
			SP	SPA	SPD	LP	IP	IC	AF	SS
NITROGEN FERTILIZER (28%, 30% & 32%)	50	0.82	U	U	U	U	U	F	G	E
NONYLPHENOL	160	1.10	U	U	U	U	U	U	U	G
OIL DISTILLATE			E	E	E	U	E	E	E	E
OIL, BUNKER 'C'	2000 - 10000	0.90	E	E	E	U	E	E	E	E
OIL, CASTOR	1500	0.96	E	E	E	U	E	E	E	E
OIL, CHINAWOOD	1425	0.94	E	E	E	U	E	E	E	E
OIL, COCONUT	148	0.93	G	G	F	U	G	G	F	E
OIL, COD LIVER	150	0.93	E	E	E	U	E	E	E	E
OIL, COOKING			G	G	G	U	G	G	G	E
OIL, CORN	150	0.93	G	G	G	U	G	G	G	E
OIL, COTTONSEED	176	0.93	E	E	E	U	E	E	E	E
OIL, CRUDE (SOUR @ 5,000PPM SULFUR)	56	0.83	U	U	G	U	U	U	G	E
OIL, CRUDE (SWEET @ 500PPM SULFUR)	110	0.86	G	G	G	U	G	G	G	E
OIL, FISH		0.93	G	G	G	U	G	G	G	E
OIL, FURNACE	37	1.1	G	G	G	U	G	G	G	E
OIL, HYDRAULIC			E	E	E	U	E	E	E	E
OIL, LINSEED	500 - 1000	0.95	G	G	G	U	G	G	G	E
OIL, LUBRICATION	200 - 4000	0.88 - 0.94	E	E	E	U	E	E	E	E
OIL, MINERAL	50	1.03	G	G	G	U	G	G	G	E
OIL, OLIVE	200	0.91	G	G	G	U	G	G	G	E
OIL, PALM	500	0.95	G	G	G	U	G	G	G	E
OIL, PEANUT	195	0.92	G	G	G	U	G	G	G	E
OIL, PEAR		0.88	U	U	G	U	G	G	G	E
OIL, PINE		0.94	G	G	G	U	G	G	G	E
OIL, RAPESEED	600	0.92	G	G	G	U	G	G	G	E
OIL, RED		0.90	U	U	G	U	G	G	G	E
OIL, RICUM		0.97	G	G	G	U	G	G	G	E
OIL, ROSIN	1500	1.08	G	G	E	U	G	G	E	E
OIL, SOYA	190	0.91	G	G	G	U	G	G	G	E
OIL, SOYBEAN	350	0.93	E	E	E	U	E	E	E	E
OIL, SUNFLOWER			G	G	G	U	G	G	G	E
OIL, TALL		0.98	U	U	G	U	U	U	G	E
OIL, TRANSFORMER			E	E	E	U	E	E	E	E
OIL, TUNG		0.94	G	G	G	U	G	G	G	E
OIL, VEGETABLE	50	0.95	G	G	G	U	G	G	G	E
OIL, WASTE (CONSULT FACTORY)			U	U	U	U	U	U	U	U
OLEUM SPIRITS		1.84	E	E	E	U	E	E	E	E
OPTILL®, HERBICIDE			U	U	U	U	F	F	E	E
ORANGE JUICE (NOT SANITARY)			U	U	U	U	U	U	U	E
ORTHO DICHLOROBENZENE	30	1.29	U	U	U	U	U	U	G	G
ORTHO XYLENE			U	U	U	U	U	G	G	G
OUTLOOK®, HERBICIDE			U	U	U	U	U	U	G	G
OXALIC ACID			U	U	U	U	U	U	U	U
OXYGEN (LIQUID CRYOGENIC)			U	U	U	U	U	U	U	U
PAINT LATEX ACETATE		0.84	U	U	U	U	G	G	G	E
PAINT LATEX ACRYLIC			U	U	U	U	G	G	G	E
PAINT LATEX VINYL			U	U	U	U	G	G	G	E
PAINT, ENAMEL			U	U	U	U	G	G	G	E
PAINT, LACQUER			U	U	U	U	G	G	G	E
PAINT, OIL BASE			U	U	U	U	G	G	G	E
PARAFFIN (MAY BE HEATED UP TO 300F)		0.90	U	U	U	U	G	G	G	E

**E = Excellent / Recommended**  
**G = Good / Minor Effect**  
**F = Fair / Moderate Effect**  
**U = Not Recommended**

This chart is intended as a chemical resistance guide rather than an unconditional rating since many system characteristics influence rate of corrosion and operation of meter; such as solution, viscosity, concentration, temperature, lubricity, presence of solids, pressure and flow rate. Ratings apply to liquids and solutions of commercial purity. Ratings do not imply Weights & Measures or UL conformance. Ratings for food type materials do not imply FDA conformance. Information compiled is based on published data and research performed by Total Control Systems. Total Control Systems cannot warranty, expressed or implied, that the laboratory results would be obtained under actual operating conditions.



SOLUTION	VISCOSITY SSU	SPECIFIC GRAVITY	700 ROTARY METER							
			SP	SPA	SPD	LP	IP	IC	AF	SS
PARAPLEX	17000		U	U	U	U	G	G	G	E
PEANUT BUTTER	10000 - 100000	1.20	U	U	U	U	U	U	U	G
PENTACHLOROPHENOL			U	U	U	U	U	U	G	E
PENTANE	30	0.63	U	U	U	E	U	U	U	U
PERCHLOROETHYLENE	30	1.63	U	U	U	U	U	U	G	E
PETROLEUM ETHER		0.60	F	G	G	U	U	G	G	E
PHENOL		1.07	U	U	U	U	F	G	G	G
PHOSPHORIC ACID (0-85%, 125F)		1.83	U	U	U	U	U	U	U	G
PHOSPHOROUS CHLORIDE			U	U	U	U	U	U	U	U
PHOSPHOROUS TRICHLORIDE			U	U	U	U	U	U	U	U
PHTHALIC ACID		1.59	U	U	U	U	G	G	U	G
PHTHALIC ANHYDRIDE		1.53	U	U	U	U	F	G	U	E
PITCH			G	G	G	U	G	G	G	E
PLASTICIZER (AVOID AIR CONTACT)		1.12	G	G	G	U	G	G	G	E
POAST®, HERBICIDE			U	U	U	U	F	F	E	E
POLYESTER RESIN	150000		U	U	U	U	G	G	G	E
POLYETHYLENE		0.90	U	U	U	U	G	G	G	E
POLYMER	4600		U	U	U	U	G	G	U	G
POLYOL	1500 - 100000		U	U	U	U	G	G	G	E
POLYPHOSPHORIC ACID			U	U	U	U	U	U	U	E
POLYPROPYLENE		0.90	G	G	G	U	G	G	G	E
POLYPROPYLENE GLYCOL (TYPE 4)	4400	1.00	G	G	G	U	G	G	G	E
POLYURETHANE RESIN			U	U	U	U	G	G	G	G
POLYVINYL ACETATE (PVAC)		1.19	U	U	U	U	G	G	G	E
POLYVINYL CHLORIDE (SUSPENSIONS)			U	U	U	U	U	U	G	E
POTASH		2.43	U	U	U	U	U	U	F	G
POTASSIUM BROMIDE			U	U	U	U	U	U	U	G
POTASSIUM CARBONATE (POTASH)			U	U	U	U	U	U	F	G
POTASSIUM HYDRATE		2.04	U	U	U	U	U	U	F	G
POTASSIUM HYDROXIDE		1.52	U	U	U	U	U	U	F	G
POTASSIUM HYPROCHLORITE			U	U	U	U	U	U	U	U
POTASSIUM NITRATE		2.11	U	U	U	U	U	U	G	G
POTASSIUM PHOSPHATE			U	U	U	U	U	U	G	G
POTASSIUM SULFATE		2.66	U	U	U	U	U	U	G	G
POUNCE®, INSECTICIDE			U	U	U	U	U	U	E	E
PREP®, DEFOLIANT			U	U	U	U	U	U	U	E
PRIMEXTRA®, HERBICIDE			U	U	U	U	F	F	E	E
PRINCEP®, HERBICIDE			U	U	U	U	F	F	E	E
PRINTING INK			G	U	U	U	G	U	G	G
PRIST		1.02	U	U	U	U	U	U	U	E
PROPANE, LIQUID (LPG)	25	0.51	U	U	U	E	U	U	U	U
PROPYL ACETATE		0.89	U	U	U	U	F	G	G	G
PROPYLENE (USE VITON SEALS)	227	0.51	U	U	U	G	U	U	U	U
PROPYLENE GLYCOL	300	1.04	G	G	G	U	G	G	G	E
PROPYLENE OXIDE		0.83	U	U	U	U	U	U	U	E
PROWL®, HERBICIDE			U	U	U	U	F	F	E	E
PURSUIT® PLUS, HERBICIDE			U	U	U	U	F	F	E	E
RESIN, PHENOLIC			U	U	U	U	G	G	G	E
RESIN (CAUSTIC)			U	U	U	U	U	U	G	E
RESIN (NEUTRAL)			U	U	U	U	G	G	G	E
ROOFING TAR			U	U	U	U	G	U	G	E

**E = Excellent / Recommended**  
**G = Good / Minor Effect**  
**F = Fair / Moderate Effect**  
**U = Not Recommended**

This chart is intended as a chemical resistance guide rather than an unconditional rating since many system characteristics influence rate of corrosion and operation of meter; such as solution, viscosity, concentration, temperature, lubricity, presence of solids, pressure and flow rate. Ratings apply to liquids and solutions of commercial purity. Ratings do not imply Weights & Measures or UL conformance. Ratings for food type materials do not imply FDA conformance. Information compiled is based on published data and research performed by Total Control Systems. Total Control Systems cannot warranty, expressed or implied, that the laboratory results would be obtained under actual operating conditions.

SOLUTION	VISCOSITY SSU	SPECIFIC GRAVITY	700 ROTARY METER							
			SP	SPA	SPD	LP	IP	IC	AF	SS
ROSIN		1.08	U	U	U	U	G	G	G	E
ROUNDUP®, HERBICIDE	31	1.01	U	U	U	U	F	F	E	E
RUBBER SOLVENT			U	U	U	U	G	G	G	E
SALICYLIC ACID		1.44	U	U	U	U	U	U	U	G
SALT BRINE			U	U	U	U	U	U	U	E
SHELLAC			F	G	G	U	G	G	G	E
SHELL-SOL			U	G	G	U	U	G	G	E
SILICONE FLUIDS			G	G	G	U	G	G	G	E
SILVER BROMIDE			U	U	U	U	U	U	U	U
SILVER NITRATE		4.33	U	U	U	U	U	U	U	G
SOAP SOLUTION			U	U	U	U	U	U	F	E
SODA ASH SOLUTION	50	1.55	U	U	U	U	U	U	G	E
SODIUM ACETATE		1.53	U	U	U	U	U	U	F	G
SODIUM ALUMINATE			U	U	U	U	U	U	G	E
SODIUM BICARBONATE (50%)		2.16	U	U	U	U	U	U	F	G
SODIUM BROMIDE		2.18	U	U	U	U	U	U	U	G
SODIUM CARBONATE		1.15	U	U	U	U	U	U	G	E
SODIUM CHLORATE			U	U	U	U	U	U	U	G
SODIUM CHLORIDE	30	2.17	U	U	U	U	U	U	G	G
SODIUM CHROMATE	60	2.72	U	U	U	U	U	U	G	G
SODIUM DICHROMATE		2.52	U	U	U	U	U	U	U	G
SODIUM FLOURIDE		2.56	U	U	U	U	U	U	U	U
SODIUM HYDROXIDE (50%, 125F)	150	1.53	U	U	U	U	U	U	G	G
SODIUM HYPOCHLORITE			U	U	U	U	U	U	U	U
SODIUM METAPHOSPHATE			U	U	U	U	U	U	G	E
SODIUM NITRATE		1.36	U	U	U	U	U	U	G	E
SODIUM PHOSPHATE		1.62	U	U	U	U	U	U	G	G
SODIUM SILICATE (AVOID AIR CONTACT)		1.56	U	U	U	U	U	U	G	E
SODIUM SULFATE		1.46	U	U	U	U	U	U	U	G
SODIUM SULFIDE		1.86	U	U	U	U	U	U	U	G
SODIUM SULFITE			U	U	U	U	U	U	U	G
SODIUM THIOSULFATE		1.23	U	U	U	U	G	G	U	E
SODIUM XYLENE SULFONATE			U	U	U	U	U	U	U	G
SONALAN®, HERBICIDE			U	U	U	U	F	F	E	E
STANNIC CHLORIDE		2.28	U	U	U	U	U	U	U	U
STARCH	100 - 100000	1.50	U	U	U	U	E	E	E	E
STARFIRE®, HERBICIDE			U	U	U	U	U	U	U	E
STEAM CONDENSATE			U	U	U	U	U	U	U	U
STEARIC ACID		0.84	U	U	U	U	G	F	U	E
STODDARD SOLVENT	30	0.78	E	E	E	U	E	E	E	E
STYRENE		0.90	E	E	E	U	E	E	E	E
SUGAR		1.69	U	U	U	U	G	U	G	E
SULFONIC ACID			U	U	U	U	U	U	F	E
SULFUR DIOXIDE			U	U	U	U	U	U	U	G
SULFURIC ACID (0-10% & 90-100%, 125F)	200	1.84	U	U	U	U	U	U	U	G
SULFURIC ACID, FUMING			U	U	U	U	U	U	U	U
SULFUROUS ACID	50	1.03	U	U	U	U	U	U	U	G
SULPHITE LIQUOR	530	1.30	U	U	U	U	U	U	U	G
SUPER BOLL®, DEFOLIANT			U	U	U	U	U	U	U	E
SURFACTANT			U	U	U	U	U	U	E	E
SURPASS®, HERBICIDE			U	U	U	U	F	F	E	E

**E = Excellent / Recommended**  
**G = Good / Minor Effect**  
**F = Fair / Moderate Effect**  
**U = Not Recommended**

This chart is intended as a chemical resistance guide rather than an unconditional rating since many system characteristics influence rate of corrosion and operation of meter; such as solution, viscosity, concentration, temperature, lubricity, presence of solids, pressure and flow rate. Ratings apply to liquids and solutions of commercial purity. Ratings do not imply Weights & Measures or UL conformance. Ratings for food type materials do not imply FDA conformance. Information compiled is based on published data and research performed by Total Control Systems. Total Control Systems cannot warranty, expressed or implied, that the laboratory results would be obtained under actual operating conditions.

SOLUTION	VISCOSITY SSU	SPECIFIC GRAVITY	700 ROTARY METER							
			SP	SPA	SPD	LP	IP	IC	AF	SS
TALLOW		0.86	U	U	U	U	G	U	G	E
TANNIC ACID		1.70	U	U	U	U	U	U	F	G
TAR			G	U	U	U	G	U	G	E
TELONE®, FUMIGANTS		1.21	U	U	U	U	U	U	U	G
TETRA ETHYL LEAD		1.63	U	U	E	U	F	G	E	E
TETRA METHYL LEAD		1.60	U	U	E	U	F	G	E	E
TETRACHLOROETHYLENE		1.59	U	U	U	U	U	U	G	E
TETRAHYDROFURAN	< 30	0.89	U	U	U	U	U	U	G	E
THERMA SEAL			U	U	U	U	U	U	U	U
THIONYL CHLORIDE			U	U	U	U	U	U	U	U
TITANIUM DIOXIDE (ABRASIVE)			U	U	U	U	U	U	U	U
TITANIUM TETRACHLORIDE			U	U	U	U	U	U	U	U
TOLUENE	30	0.87	U	U	U	U	F	E	E	E
TOLUENE DIISOCYANATE	100 - 500	1.22	U	U	U	U	U	G	G	E
TOLUOL		0.87	U	U	U	U	G	E	E	E
TOMATO PUREE (NON SANITARY)			U	U	U	U	U	U	U	G
TOPNOTCH™, HERBICIDE			U	U	U	U	F	F	E	E
TOUCHDOWN®, HERBICIDE			U	U	U	U	U	U	F	E
TOXEPHENE		1.66	U	U	U	U	U	U	U	G
TRANSMISSION FLUID	185	0.87	E	E	E	U	E	E	E	E
TREFLAN, HERBICIDE			U	U	U	U	U	U	E	E
TRIBUTYL PHOSPHATE		0.98	U	U	U	U	U	U	G	E
TRICHLOROACETIC ACID			U	U	U	U	U	U	U	U
TRICHLOROBENZENE		1.46	U	U	U	U	U	U	G	G
TRICHLOROETHANE	30	1.22	U	U	U	U	U	U	G	E
TRICHLOROETHYLENE	30	1.44	U	U	U	U	U	U	G	E
TRICRESYL PHOSPHATE		1.16	U	U	U	U	U	U	U	E
TRIETHANOLAMINE	30	1.13	U	U	U	U	F	G	G	E
TRIETHYLAMINE		0.73	U	U	U	U	U	U	G	G
TRIETHYLENE GLYCOL	250	1.13	U	U	U	U	G	G	G	E
TRIFLURALIN			U	U	U	U	U	U	G	E
TRIMETHYLPENTANE		0.69	U	U	U	G	U	U	U	U
TRISODIUM PHOSPHATE		1.62	U	U	U	U	U	U	G	G
TURPENTINE	50	0.87	E	E	E	U	E	E	E	E
UREA		1.34	U	U	U	U	U	U	G	E
URETHANE FOAM			U	U	U	U	U	U	G	G
URETHANE RESIN			U	U	U	U	U	U	G	E
VAPAM®, FUMIGANT	25		U	U	U	U	U	U	G	E
VARNISH	8000	0.90	G	G	G	U	G	G	G	E
VAR SOL	32	0.80	G	G	G	U	G	G	G	E
VEGETABLE SHORTENING	150 - 1500	0.91	U	U	U	U	G	U	F	E
VINEGAR		1.04	U	U	U	U	U	U	U	E
VINYL ACETATE	30	0.93	U	U	U	U	F	G	G	E
VINYL CHLORIDE		0.92	U	U	U	U	U	U	G	E
VINYL TOLUENE		0.89	U	U	U	U	F	G	G	E
WARRIOR®, INSECTICIDE			U	U	U	U	U	U	E	E
WATER, ACID MINE			U	U	U	U	U	U	U	G
WATER, BOILER FEED			U	U	U	U	U	U	U	U
WATER, BRACKISH			U	U	U	U	U	U	U	G
WATER, CITY	8	1.0	U	U	U	U	U	F	U	G
WATER, DEIONIZED	8	1.0	U	U	U	U	U	G	U	G

**E = Excellent / Recommended**  
**G = Good / Minor Effect**  
**F = Fair / Moderate Effect**  
**U = Not Recommended**

This chart is intended as a chemical resistance guide rather than an unconditional rating since many system characteristics influence rate of corrosion and operation of meter; such as solution, viscosity, concentration, temperature, lubricity, presence of solids, pressure and flow rate. Ratings apply to liquids and solutions of commercial purity. Ratings do not imply Weights & Measures or UL conformance. Ratings for food type materials do not imply FDA conformance. Information compiled is based on published data and research performed by Total Control Systems. Total Control Systems cannot warranty, expressed or implied, that the laboratory results would be obtained under actual operating conditions.

SOLUTION	VISCOSITY SSU	SPECIFIC GRAVITY	700 ROTARY METER							
			SP	SPA	SPD	LP	IP	IC	AF	SS
WATER, DEMINERALIZED		1.0	U	U	U	U	U	G	U	G
WATER, DISTILLED			U	U	U	U	U	G	U	G
WATER, FRESH		1.0	U	U	U	U	U	F	U	G
WATER, HARD			U	U	U	U	U	F	U	G
WATER, METHANOL			U	U	G	U	U	G	U	G
WATER, OILY			U	U	G	U	U	G	U	G
WATER, POTABLE			U	U	U	U	U	F	U	G
WATER, SALT			U	U	U	U	U	U	U	G
WATER, SEA		1.0	U	U	U	U	U	U	U	G
WATER, SOFT			U	U	U	U	U	F	U	G
WATER, TAP			U	U	U	U	U	F	U	G
WAX			G	G	G	U	G	G	G	G
WEEDMASTER®, HERBICIDE			U	U	U	U	U	U	E	E
WHEY			U	U	U	U	G	G	U	E
WHISKEY (NOT SANITARY)	150		U	U	U	U	U	U	U	E
WINE (NOT SANITARY)	30	0.96	U	U	U	U	U	U	U	E
WINDSHEILD WASHER FLUID			U	U	U	U	G	G	U	E
WOOD PRESERVATIVE			U	U	U	U	U	U	G	E
XYLENE	30	0.86	U	U	U	U	F	G	G	E
ZINC CHLORIDE			U	U	U	U	U	U	U	U
ZINC NITRATE		1.96	U	U	U	U	U	U	U	G
ZINC SULFATE		1.96	U	U	U	U	U	U	U	G

Vapam® is a registered trademark of AMVAC.

Basagran®, Clarity®, Frontier®, Galaxy®, Guardsman®, Laddok®, Marksman®, OpTill®, Outlook®, Poast®, Prowl®, Pursuit® Plus and Weedmaster® are registered trademarks of BASF Corp.

Buctril®, DEF®, Liberty® and Prep® are registered trademarks of BAYER CROPSCIENCES

Broadstrike™, FullTime®, Grazon®, Lorsban® 4E, Sonalan®, Telone® and TopNotch™ are trademarks of DOW AGROSCIENCES.

Command® and Pounce® are registered trademarks of FMC CORPORATION.

CottonQuick®, Manex® and Super Boll® is a registered trademark of GRIFFIN, L.L.C.

Freedom®, Harness®, Lasso® and Roundup® are registered trademarks of MONSANTO.

Aatrex®, Barricade®, Bicep®, Boundary®, Bravo®, Cyclone® Max, Diazinon®, DoublePlay®, Dual®, Eptam®, Gramaxone®, Primextra®, Princep®, Starfire®, Surpass®, Touchdown® and Warrior® are registered trademarks of SYNGENTA CROP PROTECTION, INC.

**E = Excellent / Recommended**  
**G = Good / Minor Effect**  
**F = Fair / Moderate Effect**  
**U = Not Recommended**

This chart is intended as a chemical resistance guide rather than an unconditional rating since many system characteristics influence rate of corrosion and operation of meter; such as solution, viscosity, concentration, temperature, lubricity, presence of solids, pressure and flow rate. Ratings apply to liquids and solutions of commercial purity. Ratings do not imply Weights & Measures or UL conformance. Ratings for food type materials do not imply FDA conformance. Information compiled is based on published data and research performed by Total Control Systems. Total Control Systems cannot warranty, expressed or implied, that the laboratory results would be obtained under actual operating conditions.

## METRIC CONVERSION GUIDE

### *U.S. System to Metric System*

### *Metric System to U.S. Systems*

	If You Know	To Find	Multiply By	If You Know	To Find	Multiply By
<b>Length:</b> Base unit is the <i>Meter</i>	mil inch foot yard mile	millimeter millimeter meter meter kilometer	0.0254 25.4 0.3048 0.9144 1.6093	millimeter millimeter meter meter kilometer	mil inch foot yard mile	39.37 0.0394 3.2808 1.0936 0.6214
<b>Area:</b> Base unit is the <i>Square Meter (m<sup>2</sup>)</i>	inch <sup>2</sup> foot <sup>2</sup> foot <sup>2</sup> yard <sup>2</sup> mile <sup>2</sup>	centimeter <sup>2</sup> centimeter <sup>2</sup> meter <sup>2</sup> meter <sup>2</sup> kilometer <sup>2</sup>	6.4516 929.03 0.0929 0.8361 2.590	centimeter <sup>2</sup> centimeter <sup>2</sup> meter <sup>2</sup> meter <sup>2</sup> kilometer <sup>2</sup>	inch <sup>2</sup> foot <sup>2</sup> foot <sup>2</sup> yard <sup>2</sup> mile <sup>2</sup>	0.155 0.0011 10.7639 1.1960 0.3861
<b>Mass:</b> Base unit is the <i>Kilogram (kg)</i>	ounce (advp.) pound pound short ton (US)	gram kilogram metric ton metric ton	28.3495 0.4536 0.00045 0.9072	gram kilogram metric ton metric ton	ounce (advp.) pound pound short ton (US)	0.03527 2.2046 2204.6 1.1023
<b>Volume/Capacity:</b> Base unit is the <i>Cubic Meter (m<sup>3</sup>)</i>	inch <sup>3</sup> fluid ounce quart (liquid) gallon (US) gallon (US) gallon (US) gallon (UK) gallon (UK) foot <sup>3</sup> yard <sup>3</sup> in <sup>3</sup> /lb ft <sup>3</sup> /lb	centimeter <sup>3</sup> centimeter <sup>3</sup> liter liter meter <sup>3</sup> gallon (UK) liter meter <sup>3</sup> meter <sup>3</sup> meter <sup>3</sup> meter <sup>3</sup> m <sup>3</sup> /kg m <sup>3</sup> /kg	16.3871 29.5735 0.9464 3.7854 0.0038 0.8327 4.456 0.00457 0.0283 0.7646 0.000036 0.0624	centimeter <sup>3</sup> centimeter <sup>3</sup> liter liter meter <sup>3</sup> gallon (UK) liter meter <sup>3</sup> meter <sup>3</sup> meter <sup>3</sup> meter <sup>3</sup> m <sup>3</sup> /kg m <sup>3</sup> /kg	inch <sup>3</sup> fluid ounce quart (liquid) gallon (US) gallon (US) gallon (US) gallon (UK) gallon (UK) foot <sup>3</sup> yard <sup>3</sup> in <sup>3</sup> /lb ft <sup>3</sup> /lb	0.061 0.0338 1.0567 0.2642 264.17 1.20095 0.21997 219.97 35.3147 1.3079 27.680 16.018
<b>Density:</b> Base unit is the <i>Cubic Meter (m<sup>3</sup>)</i>	lb/ft <sup>3</sup> lb/in <sup>3</sup> lb/gal (US)	kg/m <sup>3</sup> g/cm <sup>3</sup> kg/m <sup>3</sup>	16.0185 27.68 119.8264	kg/m <sup>3</sup> g/cm <sup>3</sup> kg/m <sup>3</sup>	lb/ft <sup>3</sup> lb/in <sup>3</sup> lb/gal (US)	0.0624 0.03613 0.008345
<b>Pressure:</b> Base unit is the <i>Pascal (P)</i>	psi psi in Hg (60°F) in H <sub>2</sub> O (60°F)	kPa bar kPa kPa	6.8948 0.0689 3.377 0.2488	kPa bar kPa kPa	psi psi in Hg (60°F) in H <sub>2</sub> O (60°F)	0.145 14.51 0.2961 4.0193
<b>Temperature:</b> Base unit is the <i>Kelvin (K)</i>	in/(in * °F) °F °F	m/(m * °C) °C K	1.8 (°F - 32)/1.8 (°F + 459.67)/1.8	m/(m * °C) °C K	in/(in * °F) °F °F	0.556 1.8°C + 32 1.8k - 459.67
<b>Velocity:</b> Base unit is the <i>Meter per Second (m/s)</i>	in/min ft/s mi/hr	cm/s m/s km/hr	0.0423 0.3048 1.6093	cm/s m/s km/hr	in/min ft/s mi/hr	23.6220 3.2808 0.6214

### STRAINER SCREEN SIZE

ASTM Mesh	Size Opening (inches)	Micron Opening
20	0.0331	841
40	0.0165	420
80	0.0070	177
100	0.0059	149
200	0.0029	74

## 700 ROTARY FLOW METER

Size	Pulse Transmitter	Meter A		Meter C			Meter D		
		1/10 <sup>th</sup> Register	1/1 Register	Plate/Shaft Mount			Direct Meter Mount		
700-15	1:1 Reed Contact	1 pulse/unit	0.1 pulse/unit	N/A	N/A	N/A	N/A	N/A	N/A
	10:1 Reed Contact	10 pulses/unit	1 pulse/unit	N/A	N/A	N/A	N/A	N/A	N/A
	100:1 Solid State	100 pulses/unit	10 pulses/unit	305.9 Pulses/USG	78.8229 Pulses/LTR	358.286 Pulses/UKG	1223.7 Pulses/USG	323.3 Pulses/LTR	1474.3 Pulses/UKG

Size	Pulse Transmitter	Meter A		Meter C			Meter D		
		1/10 <sup>th</sup> Register	1/1 Register	Plate/Shaft Mount			Direct Meter Mount		
700-20/25	1:1 Reed Contact	1 pulse/unit	0.1 pulse/unit	N/A	N/A	N/A	N/A	N/A	N/A
	10:1 Reed Contact	10 pulses/unit	1 pulse/unit	N/A	N/A	N/A	N/A	N/A	N/A
	100:1 Solid State	100 pulses/unit	10 pulses/unit	277.8 Pulses/USG	73.0164 Pulses/LTR	331.893 Pulses/UKG	555.5 Pulses/USG	146.8 Pulses/LTR	669.3 Pulses/UKG

Size	Pulse Transmitter	Meter A		Meter C			Meter D		
		1/10 <sup>th</sup> Register	1/1 Register	Plate/Shaft Mount			Direct Meter Mount		
700-30/35	1:1 Reed Contact	1 pulse/unit	0.1 pulse/unit	N/A	N/A	N/A	N/A	N/A	N/A
	10:1 Reed Contact	10 pulses/unit	1 pulse/unit	N/A	N/A	N/A	N/A	N/A	N/A
	100:1 Solid State	100 pulses/unit	10 pulses/unit	102.9 Pulses/USG	26.9390 Pulses/LTR	122.450 Pulses/UKG	205.8 Pulses/USG	54.37 Pulses/LTR	248.0 Pulses/UKG

Size	Pulse Transmitter	Meter A		Meter C			Meter D		
		1/10 <sup>th</sup> Register	1/1 Register	Plate/Shaft Mount			Direct Meter Mount		
700-40/45	1:1 Reed Contact	1 pulse/unit	0.1 pulse/unit	N/A	N/A	N/A	N/A	N/A	N/A
	10:1 Reed Contact	10 pulses/unit	1 pulse/unit	N/A	N/A	N/A	N/A	N/A	N/A
	100:1 Solid State	100 pulses/unit	10 pulses/unit	37.1 Pulses/USG	9.67720 Pulses/LTR	43.9873 Pulses/UKG	74.2 Pulses/USG	19.6 Pulses/LTR	89.4 Pulses/UKG

METER A  
METER B  
METER C  
METER D

Standard meter assembly with Veeder Root mechanical registration.

Standard meter assembly less the Veeder Root mechanical registration.

Meter and drive shaft assembly less calibration adjuster and Veeder Root mechanical registration.

Direct drive meter assembly with pulse transmitter.

## GEAR PLATE INFORMATION

TCS STANDARD	Meter	Packing Gear	Units	Registration	Type	Shafts	Ratio:1	Inverse Ratio	Rotation	Verification Test	Tenths Reading	Whole Reading	Gears	
GEAR PLATES														
VR	310450-237	700-15	4:1	US Gallons	1/10	7	Single	0.766	1.305	CCW	Rotate LEFT one (1) time	1.3	13.1	64-48-49
VR	324823-214	700-15	4:1	US Gallons - Preset	1/10	7	Double	0.766	1.305	CCW	Rotate LEFT one (1) time	1.3	13.1	64-48-49
VR	310450-524	700-15	4:1	US Gallons	Whole	5	Single	7.655	0.131	CCW	Rotate RIGHT one (1) time	0.1	1.3	35-69-35-69-33-33-65
VR	324823-510	700-15	4:1	US Gallons - Preset	Whole	5	Double	7.655	0.131	CCW	Rotate RIGHT one (1) time	0.1	1.3	35-69-35-69-33-33-65
VR	70854-260	700-15	4:1	Liters	Whole	7	Single	2.022	0.495	CCW	Rotate LEFT one (1) time	0.5	4.9	34-48-69
VR	324823-213	700-15	4:1	Liters - Preset	Whole	7	Double	2.022	0.495	CCW	Rotate LEFT one (1) time	0.5	4.9	34-48-69
VR	310450-522	700-15	4:1	Imperial Gallons	Whole	5	Single	9.183	0.109	CCW	Rotate LEFT one (1) time	0.1	1.1	28-70-49-80-28-34-63
VR	310450-238	700-20/25	2:1	US Gallons	1/10	7	Single	0.695	1.439	CCW	Rotate LEFT one (1) time	1.4	14.4	59-48-41
VR	324823-215	700-20/25	2:1	US Gallons - Preset	1/10	7	Double	0.695	1.439	CCW	Rotate LEFT one (1) time	1.4	14.4	59-48-41
VR	310450-521	700-20/25	2:1	US Gallons	Whole	5	Single	6.949	0.144	CCW	Rotate LEFT one (1) time	0.1	1.4	29-65-44-62-30-32-66
VR	324823-509	700-20/25	2:1	US Gallons - Preset	Whole	5	Double	6.949	0.144	CCW	Rotate LEFT one (1) time	0.1	1.4	29-65-44-62-30-32-66
VR	310450-523	700-20/25	2:1	Imperial Gallons	Whole	5	Single	8.338	0.120	CCW	Rotate RIGHT one (1) time	0.1	0.0	34-63-33-66-28-34-63
VR	310450-233	700-20/25	2:1	Liters	Whole	7	Single	1.836	0.545	CCW	Rotate LEFT one (1) time	0.5	5.4	31-46-57
VR	324823-204	700-20/25	2:1	Liters - Preset	Whole	7	Double	1.836	0.545	CCW	Rotate LEFT one (1) time	0.5	5.4	31-46-57
VR	310450-746	700-30/35	2:1	US Gallons	Whole	6	Single	2.575	0.388	CCW	Rotate LEFT one (1) time	0.4	3.9	43-69-43-69
VR	324823-712	700-30/35	2:1	US Gallons - Preset	Whole	6	Double	2.575	0.388	CCW	Rotate LEFT one (1) time	0.4	3.9	43-69-43-69
VR	310450-759	700-30/35	1:1	US Gallons	1/10	6	Single	0.515	1.942	CCW	Rotate RIGHT one (1) time	1.9	19.4	66-33-67-69
VR	310450-752	700-30/35	1:1	US Gallons - Preset	1/10	6	Double	0.515	1.942	CCW	Rotate RIGHT one (1) time	1.9	19.4	66-33-67-69
VR	310450-750	700-30/35	2:1	Imperial Gallons	Whole	6	Single	3.089	0.324	CCW	Rotate LEFT one (1) time	0.3	3.2	33-58-33-58
VR	326253-705	700-30/35	2:1	Liters	Whole	6	Single	0.680	1.470	CCW	Rotate LEFT one (1) time	1.5	14.7	50-68-64-32
VR	324823-711	700-30/35	2:1	Liters - Preset	Whole	6	Double	0.680	1.470	CCW	Rotate LEFT one (1) time	1.5	14.7	50-68-64-32
VR	326253-200	700-40/45	2:1	Dekaliter	Whole	7	Single	2.452	0.408	CCW	Rotate LEFT one (1) time	0.4	4.1	32-42-78
VR	324823-211	700-40/45	2:1	Dekaliter - Preset	Whole	7	Double	2.452	0.408	CCW	Rotate LEFT one (1) time	0.4	4.1	32-42-78
VR	310450-747	700-40/45	2:1	US Gallons	Whole	6	Single	0.929	1.076	CCW	Rotate LEFT one (1) time	1.1	10.8	54-49-43-44
VR	324823-713	700-40/45	2:1	US Gallons - Preset	Whole	6	Double	0.929	1.076	CCW	Rotate LEFT one (1) time	1.1	10.8	54-49-43-44
VR	310450-751	700-40/45	2:1	Imperial Gallons	Whole	6	Single	1.114	0.898	CCW	Rotate LEFT one (1) time	0.9	9.0	66-42-28-49
VR	326253-704	700-40/45	2:1	Liters	Whole	6	Single	0.245	4.078	CCW	Rotate LEFT one (1) time	4.1	40.8	57-28-60-30
VR	324823-710	700-40/45	2:1	Liters - Preset	Whole	6	Double	0.245	4.078	CCW	Rotate LEFT one (1) time	4.1	40.8	57-28-60-30

# APPROXIMATE WEIGHT

Pounds (Kilograms)		TCS Flow Meter	V/R Register Counter	V/R Preset Counter	V/R Ticket Printer	Mechanical Preset Valve	Electronic Preset Valve	Air Eliminator (Inline)	Air Eliminator & Strainer	Air Eliminator/ High Volume Strainer	Strainer & Cover	Air Check Valve
700-15	SP	21 (9.5)	12 (5.4)	10 (4.5)	12 (5.4)	7 (3.2)	13 (5.9)	-	17 (7.7)	-	9 (4.1)	7 (3.2)
	SPA	21 (9.5)	12 (5.4)	10 (4.5)	12 (5.4)	7 (3.2)	13 (5.9)	-	17 (7.7)	-	9 (4.1)	7 (3.2)
	IP	21 (9.5)	12 (5.4)	10 (4.5)	12 (5.4)	7 (3.2)	-	-	17 (7.7)	-	9 (4.1)	7 (3.2)
	IC	21 (9.5)	12 (5.4)	10 (4.5)	12 (5.4)	7 (3.2)	-	-	17 (7.7)	-	9 (4.1)	7 (3.2)
700-20	SP	24 (11.8)	12 (5.4)	10 (4.5)	12 (5.4)	7 (3.2)	13 (5.9)	-	17 (7.7)	32 (14.5)	9 (4.1)	7 (3.2)
	SPA	24 (11.8)	12 (5.4)	10 (4.5)	12 (5.4)	7 (3.2)	13 (5.9)	-	17 (7.7)	32 (14.5)	9 (4.1)	7 (3.2)
	SPD	52 (22.7)	12 (5.4)	10 (4.5)	12 (5.4)	16 (7.3)	-	-	39 (17.8)	-	19 (8.6)	-
	IP	24 (11.8)	12 (5.4)	10 (4.5)	12 (5.4)	7 (3.2)	-	-	17 (7.7)	-	9 (4.1)	7 (3.2)
	IC	24 (11.8)	12 (5.4)	10 (4.5)	12 (5.4)	7 (3.2)	-	-	17 (7.7)	-	9 (4.1)	7 (3.2)
	AF	52 (22.7)	12 (5.4)	10 (4.5)	12 (5.4)	16 (7.3)	-	-	39 (17.8)	-	19 (8.6)	-
	SS	54 (22.7)	12 (5.4)	10 (4.5)	12 (5.4)	16 (7.3)	-	-	45 (20.4)	-	21 (9.5)	-
700-25	SPA	24 (11.8)	12 (5.4)	10 (4.5)	12 (5.4)	7 (3.2)	13 (5.9)	-	17 (7.7)	32 (14.5)	9 (4.1)	7 (3.2)
	SPD	52 (22.7)	12 (5.4)	10 (4.5)	12 (5.4)	16 (7.3)	-	-	39 (17.8)	-	19 (8.6)	-
700-30	SP	53 (24.0)	12 (5.4)	10 (4.5)	12 (5.4)	12 (5.4)	17 (7.7)	-	20 (9.1)	37 (16.8)	13 (5.9)	12 (5.4)
	SPA	53 (24.0)	12 (5.4)	10 (4.5)	12 (5.4)	12 (5.4)	17 (7.7)	-	20 (9.1)	37 (16.8)	13 (5.9)	12 (5.4)
	SPD	125 (56.7)	12 (5.4)	10 (4.5)	12 (5.4)	-	-	-	59 (26.8)	-	38 (17.2)	-
	IP	53 (24.0)	12 (5.4)	10 (4.5)	12 (5.4)	12 (5.4)	-	-	20 (9.1)	-	13 (5.9)	12 (5.4)
	IC	53 (24.0)	12 (5.4)	10 (4.5)	12 (5.4)	12 (5.4)	-	-	20 (9.1)	-	13 (5.9)	12 (5.4)
	AF	125 (56.7)	12 (5.4)	10 (4.5)	12 (5.4)	-	-	-	59 (26.8)	-	38 (17.2)	-
700-35	SPA	53 (24.0)	12 (5.4)	10 (4.5)	12 (5.4)	12 (5.4)	17 (7.7)	-	20 (9.1)	37 (16.8)	13 (5.9)	12 (5.4)
	SPD	125 (56.7)	12 (5.4)	10 (4.5)	12 (5.4)	-	-	-	59 (26.8)	-	38 (17.2)	-
700-40	SP	110 (49.9)	12 (5.4)	10 (4.5)	12 (5.4)	17 (7.7)	-	134 (60.8)	32 (14.5)	-	25 (11.3)	-
	SPA	110 (49.9)	12 (5.4)	10 (4.5)	12 (5.4)	17 (7.7)	-	134 (60.8)	32 (14.5)	-	25 (11.3)	-
	SPD	275 (124.7)	12 (5.4)	10 (4.5)	12 (5.4)	-	-	144 (65.3)	74 (33.6)	-	53 (24.0)	-
	IP	110 (49.9)	12 (5.4)	10 (4.5)	12 (5.4)	17 (7.7)	-	134 (60.8)	32 (14.5)	-	25 (11.3)	-
	IC	110 (49.9)	12 (5.4)	10 (4.5)	12 (5.4)	17 (7.7)	-	134 (60.8)	32 (14.5)	-	25 (11.3)	-
	AF	275 (124.7)	12 (5.4)	10 (4.5)	12 (5.4)	-	-	144 (65.3)	74 (33.6)	-	53 (24.0)	-
700-45	SPA	110 (49.9)	12 (5.4)	10 (4.5)	12 (5.4)	-	-	134 (60.8)	32 (14.5)	-	25 (11.3)	-
	SPD	275 (124.7)	12 (5.4)	10 (4.5)	12 (5.4)	-	-	144 (65.3)	74 (33.6)	-	53 (24.0)	-



## GLOSSARY

Acceptance Test: A original test of a new device under carefully controlled conditions and with expert operators, to determine that the device will comply with the accuracy requirements for Weights and Measures approval to be used as a resale device.

Accessories (Auxiliary Equipment): Items used with a measuring device to facilitate the use of the information obtained from it. Also, items furnished to improve its performance, such as strainers, air eliminators, valves, etc.

Accumulative: A term applied to indicating elements or recording elements to describe the fact that they are not resettable to a zero indication in normal use.

Accuracy: Freedom from error, usually expressed in percentage.

Accuracy Curve: A graph or plotted curve showing the performance characteristics of a measuring device. The information plotted is the amount of error at the rates of flow between the minimum and maximum rated capacity of the device.

Adjustor: A ratio changing device which is used to obtain agreement between the indicated and/or recorded volume and the actual volume measured. The ration may be either continuously variable or variable in increments.

Air Eliminator (Air Release) (Vapor Eliminator): A device installed upstream of the measuring device to avoid measuring air or vapor. Air or vapor measured with liquid will result in registering a volume larger than the liquid volume.

Air Separator: A device of the air eliminator type designed to include the capability of separating air or vapor intimately mixed with the liquid. It may include one or more air eliminator mechanisms and usually incorporates a greater volume or other means for achieving separation.

Air (Vapor) Control System: An arrangement of various elements intended to assist the air eliminator – or air separator – by stopping or reducing flow of liquid when air or vapor is detected. May have various trade names.

Ambient Temperature: Literally, this is the temperature of the surroundings. It is usually used to denote the temperature of the atmosphere in a given location at a specific time.

Analog Device: A device in which the indicated quantity is a constantly changing amount, which indicates directly the amount being measured. An example is the pointer on a clock or a continuous motion type indicator. In reading this for the delivered quantity, it may be necessary to estimate the fractional units.

Analog Device: A device in which the indicated quantity is a constantly changing amount, which indicates directly the amount being measured. An example is the pointer on a clock or a continuous motion type indicator. In reading this for the delivered quantity, it may be necessary to estimate the fractional units.

Back Pressure Valve: A device intended to maintain a desired minimum upstream pressure.

Bubble Point: The conditions of temperature and pressure under which a liquid will begin to form vapor.

Calibration: The procedure of setting or bringing a meter or a prover into agreement with an established standard.

Check Valve (Non-return Valve): A device designed to prevent a reversal of flow of liquid.

Clingage: The liquid film that adheres to the inside surface of a container after it has been emptied.

Coefficient of Expansion: A number usually expressed as a decimal that indicates the change of volume per unit of volume per degree of temperature change.

Counter (Register): A device which indicates a quantity related to the volume measured by the meter.

Delivery, Over – Delivery, Under: The terms, over-delivery and under-delivery, are commonly used to indicate the kind of measuring error that is experienced.

Density, Relative: The relative density  $t_1/t_2$  of a solid liquid substance is defined as the ratio of the mass of a given volume of the substance at a temperature  $t_1$  to the mass of an equal volume of pure water at a temperature  $t_2$  (this term replaces the normal term “specific gravity”).

Differential Pressure Valve: A device designed to maintain the total pressure in a system at a desired pressure higher than the vapor pressure of the liquid when being metered.

Digital Device: A device in which the indication of the measured quantity changes by finite increments, which may be units, fractions, or decimals.

Digital Signal: Transmitted information that takes the form of a series of individual distinct signals. These are commonly called pulses.

Drainage Time: The drainage time for test measures and provers shall be 10 seconds for a capacity of 10 gallons or less, and 30 seconds for capacities exceeding 10 gallons. Necessary to achieve uniform clingage film.

Error: The difference between the indicated value and the true value.

Flow Limiting Device (Flow Control): A device installed in the system to prevent the rate of flow through the meter from exceeding the desired maximum flow rate.

Flow Meter: Commonly used to describe a liquid measuring device that indicates the rate of flow in terms of velocity or as units of volume per unit of time.

Flow Range: The minimum and maximum flow rates established by the manufacturer to provide the maximum meter performance and accuracy with long life. If exceeded, accuracy or meter life may be adversely affected.

Flow Rate (Rate of Flow): The rate of flow of liquid expressed in volume or mass units per unit of time.

Gravity, Specific: See Density, Relative.

Laminar Flow: Liquid flow in which the liquid elements travel along relatively straight parallel paths.

Low Vapor Pressure Liquid: A liquid, which at atmospheric pressure and temperature can be maintained in an open system without boiling.

Maintenance Tolerance: A tolerance test made at the maximum discharge rate that maybe anticipated under the conditions of installation after the initial acceptance testing has been successfully completed.

Master Meter: A meter used as a reference for testing other working meters.

Meniscus: The curved surface at the end of a liquid column.

Non-return Valve (Check Valve): A device designed to prevent a reversal of flow.

Normal Test: A test made at the maximum discharge rate that may be anticipated under the conditions of installation. (If equipped with an automatic temperature compensator, the meter should be tested with the temperature compensator deactivated.) Any additional test conducted at flow rates down to and including one-half of the sum of the maximum discharge flow rate and the rated minimum discharge flow rate shall be considered normal tests.

Positive Displacement Meter: A meter in which the primary sensing element separates the liquid into measured segments of known volume providing a shaft motion or other signal that can be used for indicating the volume delivered.

Preset Device: An indicating device that can be preset for a desired quantity which will stop the flow automatically, or provide a signal when the preselected quantity of liquid has been metered or “delivered”.

Pressure Loss (Pressure Drop) (Loss of Head) (Differential Pressure): The difference in pressure between the inlet and outlet of a device while operating.

Prover (Proving Tank): Volumetric Type. A closed or open vessel designed especially for accurate determination of the volume of a liquid delivered into or out of it during a meter run. The volume of liquid is either observed from the liquid level in a gage proving glass or known from previous calibration of a fixed-volume vessel. The volume is greater than ten gallons. See Test Measure.

Recording Element: A device designed to print the volume metered on a ticket, slip, tape, or card.

Reference Standard: A volumetric measure that has been verified to “contain” or to “deliver” a known volume and which is used for establishing the volume of field and working standards.

Register (Counter): A device, which indicates the quantity measured by the meter.

Registration, Over – Registration, Under: The terms, over-registration and under-registration, are commonly used to indicate the kind of measuring error that is experienced. Over-registration indicates the counter is registering a greater volume than is delivered by the meter, and under-registration indicates that the meter is delivering more than is registered on the counter.

Repeatability: A measure of the deviation as a series of test results from their mean value, all determinations being carried out under identical conditions.

Special Test: Any test other than a “Normal” test. A special test is defined as a test “to develop the operating characteristics of a liquid measuring device and any special elements and accessories attached to or associated with the device. Special test of a measuring system shall be made at a minimum discharge rate of 20% of the marked maximum discharge rate or at the minimum discharge rate marked on the device whichever is less.

Split Compartment Test: A test applied to a truck mounted metering system, which simulates the conditions encountered in actual operation when one truck compartment is emptied during a delivering and the delivery is completed from another compartment.

Strainer (Filter): A device equipped with a porous medium or wire mesh element to prevent particles of foreign material from passing through a meter.

Test Measure: Vessels designed especially for the precision measurement of liquid having verified capacities of 1, 5, or 10 gallons. These are usually certified for accuracy of measurement by the National Bureau of Standards.

Tolerance: The amount of error that will be allowed. It is a plus or minus value.

Torque Load: The power required of the meter for driving accessory equipment such as counters, printer, etc.

True Value: The theoretically correct amount. In every day use it is represented by the Standard being used for comparison.

Vapor Eliminator (Vapor Release): A device installed upstream of the measuring device to avoid measuring air and/or vapor.

# MATERIAL SAFETY DATA SHEET

24 HOUR EMERGENCY ASSISTANCE  
(260) 833-3173

GENERAL MSDS ASSISTANCE  
(260) 484-0301

CODE: RPS

HAZARD RATING> LEAST-0 SLIGHT-1 MODERATE-2 HIGH-3 EXTREME-4

DR LUBRICANTS, INC.  
4611 NEWAYGO ROAD, SUITE D  
FORT WAYNE, IN 46808

DATE: 01/21/06  
TELEPHONE: (260) 484-0301

## SECTION I - PRODUCT IDENTIFICATION

PRODUCT: **RP 1039**

## SECTION II - COMPOSITION AND HAZARDOUS INFORMATION\*

CHEMICAL NAME	CAS NUMBER	WT. PERCENT IS LESS THAN	OCCUPATIONAL EXPOSURE LIMITS (TLV-TWA) (TLV-STEL)
PETROLEUM HYDROCARBON	64741-65-7	90.0	100MG/M3
PETROLEUM HYDROCARBON	64742-53-6	10.0	5MG/M3

\*ITEMS NOT SHOWN ARE NOT LISTED IN THE OSHA - T.S.C.A. HAZARDOUS CHEMICALS LISTING.

## SECTION III - PHYSICAL DATA

BOILING RANGE:	NA	VAPOR DENSITY:	NA
ODOR:	PETROLEUM ODOR	EVAPORATION RATE:	NA
APPEARANCE	AMBER LIQUID	SOLUBILITY:	INSOLUBLE
VOLATILE BY WEIGHT:	NA	PRODUCT DENSITY:	0.790
VOLATILE BY VOLUME:	NA		

## SECTION IV - FIRE AND EXPLOSION HAZARD DATA

FLAMMABILITY CLASSIFICATION:	COMBUSTIBLE	FLASH POINT: 150 F (CLEVELAND OPEN CUP)	LEL:NA UEL:NA
DOT:	COMBUSTIBLE LIQUID		
EXTINGUISHING MEDIA:	CARBON DIOXIDE, DRY CHEMICAL, FOAM		

SECTION IV - FIRE AND EXPLOSION HAZARD DATA

UNUSUAL FIRE AND EXPLOSION HAZARDS : DO NOT DIRECT A SOLID STREAM OF WATER ONTO BURNING PRODUCT. THIS MAY CAUSE SPREADING AND INCREASE THE FIRES INTENSITY. COMBUSTION MAY PRODUCE: OXIDES OF CARBON, AND INCOMPLETELY BURNED HYDROCARBONS IN THE FORM OF FUMES AND SMOKE.

SPECIAL FIREFIGHTING PROCEDURES: WEAR A SELF-CONTAINED BREATHING APPARATUS WITH FULL FACEPIECE.

SECTION V - HEALTH HAZARD DATA

EFFECTS OF OVER EXPOSURE: MAY CAUSE MILD EYE IRRITATION AND REDNESS. PROLONGED OR REPEATED EXPOSURE TO THE SKIN MAY RESULT IN LOSS OF NATURAL OILS ACCOMPANIED BY DRYNESS, CRACKING AND DERMATITIS. INGESTION MAY RESULT IN NAUSEA, DIARRHEA AND GASTRO INTESTINAL IRRITATION. OVEREXPOSURE TO MIST MAY CAUSE UPPER RESPIRATORY TRACT IRRITATION AND DIFFICULTY BREATHING.

MEDICAL CONDITIONS PRONE TO AGGRAVATION BY EXPOSURE: NONE KNOWN.

PRIMARY ROUTE(S) OF ENTRY: DERMAL INHALATION INGESTION.

EMERGENCY AND FIRST AID PROCEDURES: IN CASE OF EYE CONTACT, IMMEDIATELY FLUSH EYES WITH CLEAN WATER FOR AT LEAST 15 MINUTES. IF EYE IRRITATION PERSISTS, CONTACT A PHYSICIAN. IN CASE OF SKIN CONTACT, REMOVE ANY CONTAMINATED CLOTHING AND RINSE SKIN THOROUGHLY WITH WATER FOR AT LEAST 15 MINUTES. IF SKIN IRRITATION PERSISTS, CONTACT A PHYSICIAN. IN CASE OF OVEREXPOSURE TO MIST, REMOVE VICTIM TO FRESH AIR: IF BREATHING IS DIFFICULT ADMINISTER OXYGEN: AND CONTACT A PHYSICIAN IMMEDIATELY. IF PRODUCT IS INGESTED DO NOT INDUCE VOMITING: CONTACT A PHYSICIAN.

SECTION VI - REACTIVITY DATA

STABILITY: THIS PRODUCT IS STABLE UNDER NORMAL STORAGE CONDITIONS.

HAZARDOUS POLYMERIZATION: WILL NOT OCCUR UNDER NORMAL CONDITIONS.

HAZARDOUS DECOMPOSITION PRODUCTS: THERMAL DECOMPOSITION MAY RESULT IN THE FORMATION OF: OXIDES OF CARBON, AND INCOMPLETELY BURNED HYDROCARBONS IN THE FORM OF FUMES AND SMOKE.

CONDITIONS TO AVOID: AVOID CONTACT WITH OPEN FLAME, STORE IN ROOM TEMPERATURE AREA.

INCOMPATIBILITY: AVOID CONTACT WITH STRONG OXIDIZING AND REDUCING AGENTS AND STRONG ALKLI.

=====

SECTION VII - SPILL OR LEAK PROCEDURES

=====

STEPS TO BE TAKEN IN CASE MATERIAL IS RELEASED OR SPILLED: FOR SMALL SPILLS: SOAK UP SPILL WITH ABSORBENT MATERIAL. FOR LARGE SPILLS: DIKE SPILL AND PUMP INTO DRUMS FOR PROPER DISPOSAL.

WASTE DISPOSAL METHOD: DISPOSE OF IN ACCORDANCE WITH ALL LOCAL STATE AND FEDERAL REGULATIONS.

=====

SECTION VIII - SAFE HANDLING AND USE INFORMATION

=====

RESPIRATORY PROTECTION: NORMALLY NOT REQUIRED, HOWEVER, WHEN THE TLV IS EXCEEDED WEAR THE APPROPRIATE MSHA/NIOSH APPROVED RESPIRATOR.

VENTILATION: PROVIDE ADEQUATE VENTILATION (SUCH AS MECHANICAL OR LOCAL) TO ASSURE TLV IS NOT EXCEEDED.

PROTECTIVE GLOVES: NORMALLY NOT REQUIRED, HOWEVER, IF HANDS ARE FREQUENTLY IN FLUID WEAR OIL AND CHEMICAL IMPERVIOUS GLOVES.

EYE PROTECTION: SAFETY GLASSES REQUIRED FOR NORMAL USAGE, WEAR CHEMICAL GOGGLES WHEN EXCESSIVE SPLASHING MAY OCCUR.

OTHER PROTECTIVE EQUIPMENT: NORMALLY NOT REQUIRED, HOWEVER, WHERE REPEATED CONTACT OCCURS, WEAR IMPERVIOUS CLOTHING AND BOOTS.

HYGIENIC PRACTICES: FOLLOW STANDARD INDUSTRIAL HYGIENE PRACTICES. LAUNDRY ANY CONTAMINATED CLOTHING BEFORE RE-USE.

=====

SECTION IX - SPECIAL PRECAUTIONS

=====

PRECAUTIONS TO BE TAKEN IN HANDLING AND STORAGE: DO NOT STORE IN THE PRESENCE OF HEAT, SPARKS, FLAME OR ANY OTHER SOURCES OF IGNITION. STORE AWAY FROM STRONG OXIDIZING AGENTS. EMPTY DRUMS MAY CONTAIN PRODUCT RESIDUES. ALL SAFETY PRECAUTIONS TAKEN WHEN HANDLING THIS PRODUCT SHOULD ALSO BE TAKEN WHEN HANDLING EMPTY DRUMS AND CONTAINERS.

OTHER PRECAUTIONS: NONE

=====

SECTION X - HMIS/NFPA RATINGS

=====

HMIS:HEALTH:1	FLAMMABILITY:2	REACTIVITY:0	PERSONAL PROTECTION:C
NFPA:HEALTH:1	FLAMMABILITY:2	REACTIVITY:0	SPECIFIC HAZARD:

=====

SECTION XI - OTHER REGULATORY INFORMATION

=====

DOT HAZARDOUS:      NATURAL DESCRIPTION:

=====

THE INFORMATION CONTAINED HEREIN IS, TO THE BEST OF OUR KNOWLEDGE AND BELIEF, ACCURATE. HOWEVER, SINCE THE CONDITIONS OF HANDLING AND USE ARE BEYOND OUR CONTROL, WE MAKE NO GUARANTEE OF RESULTS, AND ASSUME NO LIABILITY FOR DAMAGES INCURRED BY USE OF THIS MATERIAL. IT IS THE RESPONSIBILITY OF THE USER TO COMPLY WITH ALL APPLICABLE FEDERAL, STATE AND LOCAL LAWS AND REGULATIONS.

=====

